

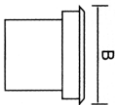

Dimensiones (mm)

A: 110; **B:** 45
C: 55.

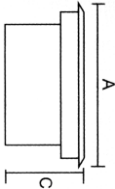

Código

HF-601A

Descripción

Luminaria tipo aplique, diseñada con LED integrado. Para empotrar, con difusor en vidrio templado.



Materiales y acabado

Cuerpo en aluminio inyectado y chasis exterior en plástico inyectado.

Color

Marco plateado.

Características técnicas

LED	 82°	 20,000h	IP 54	IK 04
PF 0,33	THD <40%	°C 0-55	V 120-240	Hz 50

Fuente de luz

LED.

Potencia	CRI	K	Lm / W	Lm de Salida
1,4W	>80	3000	45	22,1

Características de fuente de luz

- Color temperatura disponible 3000K (cálido).

Light efficiency:



Light quality:



Color temperature:



Output: 22,1 lm

Peak: 13,3 cd

Power: 1,4 W

PF: 0,33



Product name:
E0357-HF601A

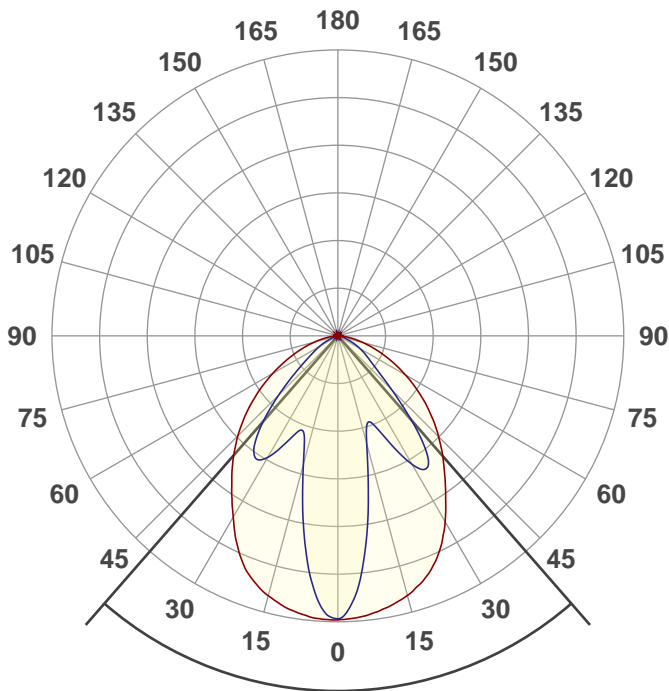

Beam angle
82,2°



CIE 1931
x: 0,440
y: 0,400

THD Values:

Voltage: 2,94%

Current: 34,97%

Spectra

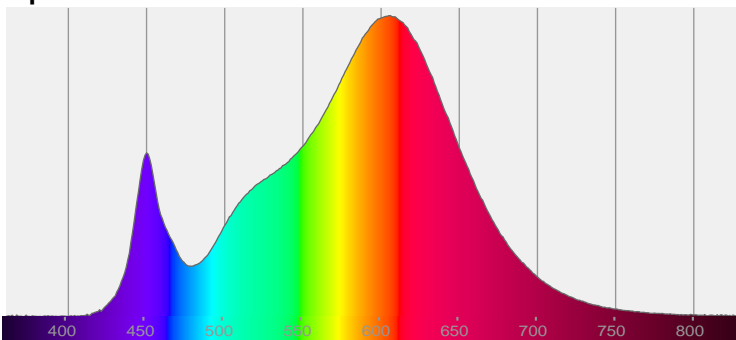

Power

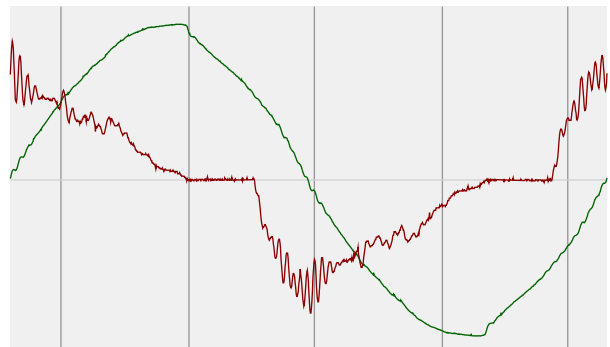

Voltage: 116 V
Current: 0,013 A
Frequency: 60 Hz

Color details

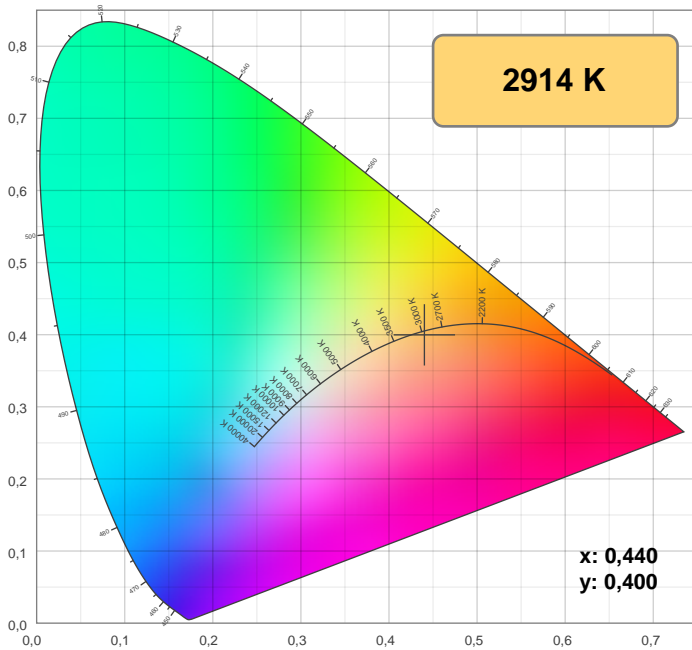

CIE 1931

CRI: 82,5 (R1-R8)

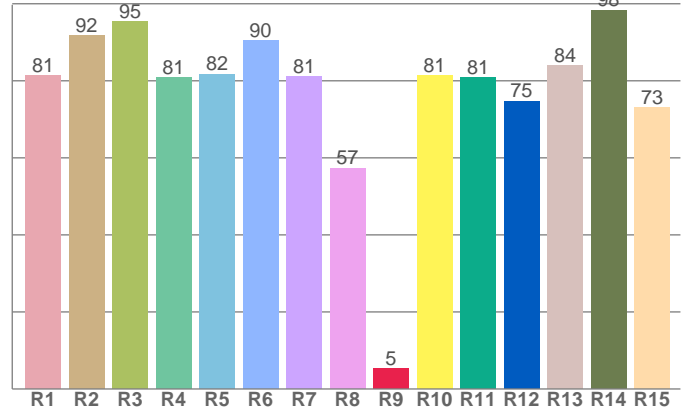

CRI R values, only R1-R8 are used to calculate final CRI value

R1	R2	R3	R4	R5	R6	R7	R8	9	R10	R11	R12	R13	R14	R15
81,3	91,7	95,4	80,7	81,8	90,4	81,1	57,3	5,3	81,4	80,8	74,7	84,0	98,3	73,0

ISO Diagrams

ISO lux diagram

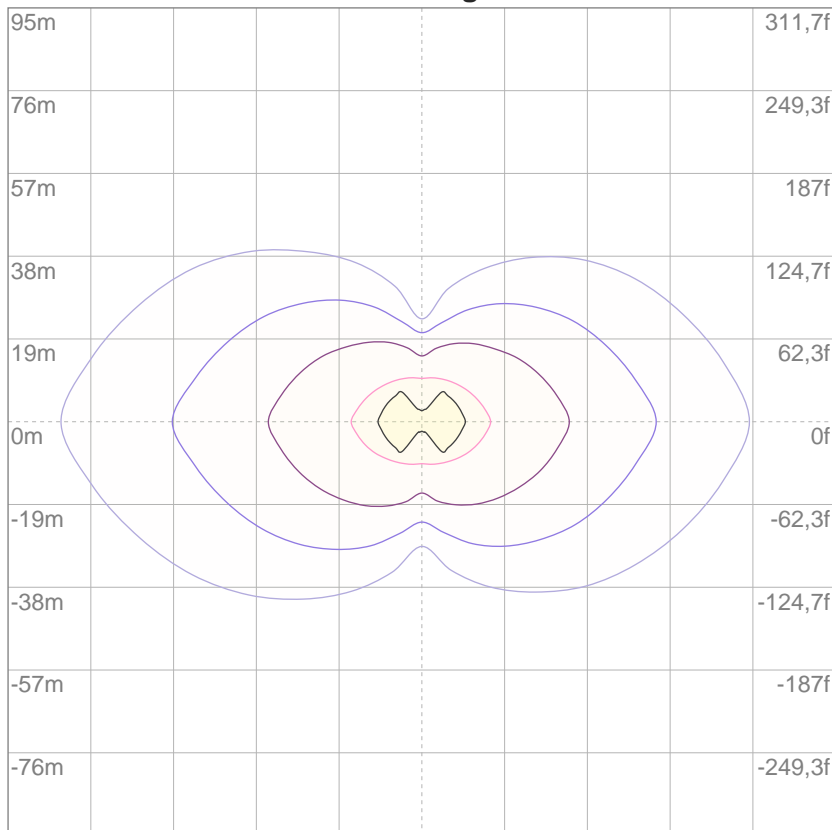

Mounting height: 10 meters (33 f)

- 3% 3,99m lx
- 5% 6,65m lx
- 10% 13,3m lx
- 30% 39,9m lx
- 50% 66,5m lx

Conditions:

Number of c-planes: 4

Lux at center: 0,133 lx

Lux distribution on a surface when lamp is mounted at 10 meters from the surface.

Beam details

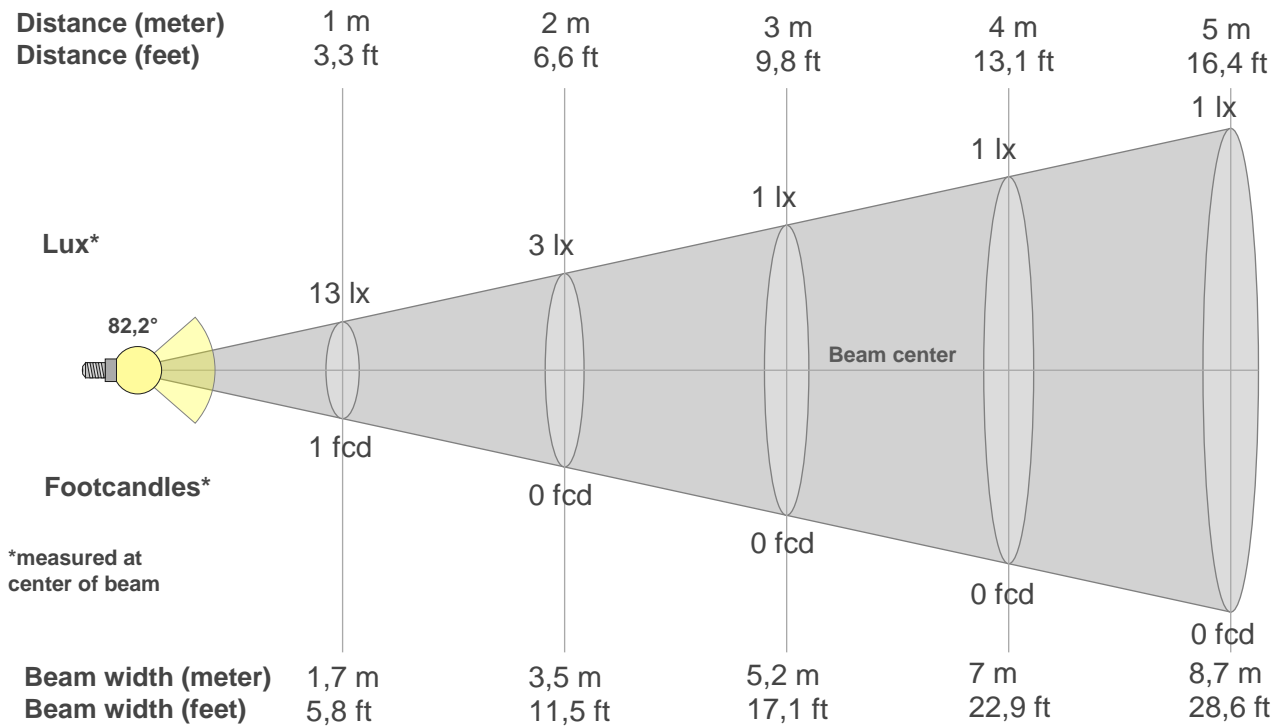

Beam intensities from 1-20m

1m	2m	3m	4m	5m	6m	7m	8m	9m	10m	11m	12m	13m	14m	15m	16m	17m	18m	19m	20m
3,3ft	6,6ft	9,8ft	13,1ft	16,4ft	19,7ft	23ft	26,2ft	29,5ft	32,8ft	36,1ft	39,4ft	42,7ft	45,9ft	49,2ft	52,5ft	55,8ft	59,1ft	62,3ft	65,6ft
13lx	3lx	1lx	1lx	1lx	0lx	0lx	0lx	0lx	0lx	0lx	0lx	0lx	0lx	0lx	0lx	0lx	0lx	0lx	0lx
1,2fcd	0,3fcd	0,1fcd	0,1fcd	0fcd	0fcd	0fcd	0fcd	0fcd	0fcd	0fcd	0fcd	0fcd	0fcd	0fcd	0fcd	0fcd	0fcd	0fcd	0fcd

Intensities in 0° c-plane

0°	5°	10°	15°	20°	25°	30°	35°	40°	45°	50°	55°	60°	65°	70°	75°	80°	85°	90°	95°
13,3	13,2	13,0	12,6	12,1	11,2	10,1	8,8	7,7	6,7	5,7	4,6	3,7	2,7	1,9	1,2	0,7	0,3	0,1	0,1
100%	99%	98%	95%	91%	84%	76%	66%	58%	50%	43%	35%	27%	21%	14%	9%	5%	2%	1%	1%

Intensities in 90° c-plane

0°	5°	10°	15°	20°	25°	30°	35°	40°	45°	50°	55°	60°	65°	70°	75°	80°	85°	90°	95°
13,3	11,6	8,2	5,2	4,3	5,3	7,0	7,4	5,8	3,6	2,3	1,7	1,2	0,8	0,4	0,2	0,1	0,1	0,1	0,1
100%	87%	62%	39%	32%	40%	52%	56%	43%	27%	17%	12%	9%	6%	3%	2%	1%	1%	0%	1%

Intensities in 180° c-plane

0°	5°	10°	15°	20°	25°	30°	35°	40°	45°	50°	55°	60°	65°	70°	75°	80°	85°	90°	95°
13,3	13,3	13,0	12,6	12,0	11,1	9,8	8,7	7,7	6,6	5,6	4,5	3,5	2,6	1,8	1,2	0,6	0,2	0,0	0,0
100%	100%	98%	95%	90%	83%	74%	65%	58%	50%	42%	34%	27%	20%	14%	9%	5%	2%	0%	0%

Intensities in 270° c-plane

0°	5°	10°	15°	20°	25°	30°	35°	40°	45°	50°	55°	60°	65°	70°	75°	80°	85°	90°	95°
13,3	12,1	9,2	6,3	4,8	5,4	6,6	6,8	5,7	3,9	2,4	1,5	1,0	0,6	0,3	0,2	0,1	0,1	0,1	0,1
100%	91%	69%	47%	36%	40%	49%	51%	43%	30%	18%	11%	8%	4%	2%	1%	1%	1%	1%	1%

Beam angle 50%	Field angle 10%	Cutoff angle 2,5%	Intensity ratio in 120° cone	Intensity ratio in 90° cone
82,2°	131,4°	154,3°	87,3%	66,4%

TM30 details

Rf 82,4
Fidelity index Rf

Rg 96,9
Gammut index Rg

Hue Bin	R _f	Graphic shifts (%)	
		Chroma	Hue
1	77	-12%	0%
2	78	-8%	8%
3	73	-3%	12%
4	86	2%	7%
5	92	4%	4%
6	90	4%	-3%
7	84	-2%	-8%
8	92	-3%	-3%
9	88	-6%	2%
10	83	-5%	9%
11	80	-1%	13%
12	83	7%	3%
13	85	6%	-7%
14	77	6%	-16%
15	81	-2%	-10%
16	73	-9%	-17%

