

Código

KT6355-12W-4K

Descripción

Luminaria tipo bala, recesada, diseñada con módulo de LED. Para empotrar al techo por medio de sujetadores ubicados en los laterales. Compuesta con difusor en acrílico transparente.



Materiales y acabado

Sujetadores y resortes en hierro con acabado galvanizado. Cuerpo y aro en aluminio inyectado, con acabado en pintura poliéster electrostática.

Color

Blanco.

Características técnicas

LED	 66°	 50,000h	IP 20	IK 02
PF 0,99	THD <10%	°C 0-40	V 100-240	Hz 50/60

Fuente de luz

Bala con módulo de LED.

Potencia Nominal	CRI	K	Lm / W	Lm de Salida
12W	>80	4000	125	1303

Características de fuente de luz

- Tipo de color temperatura 4000K (neutro).
- Potencia de Salida: 10,4W.



Dimensiones (mm)

Altura: 84
Diámetro: Ø170.

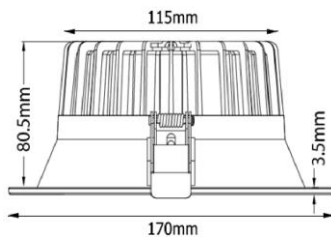

Instalación

Se debe tener en cuenta la alimentación de la luminaria, para ubicarla.

1. Realizar una perforación en el techo (drywall, madera), en donde desea ubicar la luminaria con un diámetro de Ø140 mm.

2. Sujetar los ganchos de fijación, ubicados en los laterales de la luminaria. Para insertar está en la perforación previamente realizada.

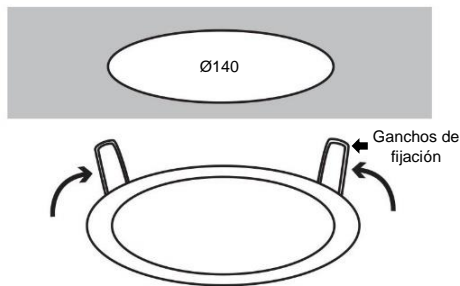

3. Soltar los ganchos una vez que se encuentre la luminaria dentro de la perforación del techo. Asegurarse que la luminaria quede ajustada en el techo.

Mantenimiento de las luminarias

Es esencial llevar a cabo periódicamente inspecciones y mantenimiento a las luminarias instaladas, ya que estas reciben influencia de las condiciones de operación y del medio donde se ubican.

1. Mantenimiento correctivo

El mantenimiento correctivo de las luminarias consiste en localizar, reparar y adecuar las instalaciones para que funcionen el máximo número de horas posible, con el desempeño para el que fueron diseñadas.

Las actividades que componen el mantenimiento correctivo son:

- Localización y reparación de averías
- Adecuación de instalaciones

Para la ejecución del mantenimiento correctivo es importante tener en cuenta los siguientes aspectos:

- Si se genera algún inconveniente en el LED por favor comunicarse con la empresa.
- Revisar el encendido, apagado y el correcto funcionamiento de la luminaria.
- Limpiar el conjunto óptico de las luminarias con aire comprimido. Para manipular la luminaria se recomienda utilizar guantes quirúrgicos.

2. Mantenimiento preventivo

Dentro de las técnicas de diagnóstico se deben considerar las mediciones eléctricas en diferentes puntos de la red, así como la medición de parámetros eléctricos de operación de las luminarias y sus componentes.

3. Mantenimiento de las instalaciones eléctricas de las luminarias

La persona encargada de la operación y el mantenimiento de las instalaciones eléctricas de las luminarias será responsable de mantenerlas en condiciones seguras, por lo tanto deben garantizar que se cumplan las disposiciones del reglamento que establece los requisitos que deben cumplir los sistemas de alumbrado y verificar que estas conexiones no presenten ningún riesgo para la salud o la vida de las personas, animales o el medio ambiente.

Light efficiency:



Light quality:



Color temperature:



Output: 1303 lm

Peak: 1155 cd

Power: 10,4 W

PF: 0,99



Product name:
E0113-KT6355-12W-4K

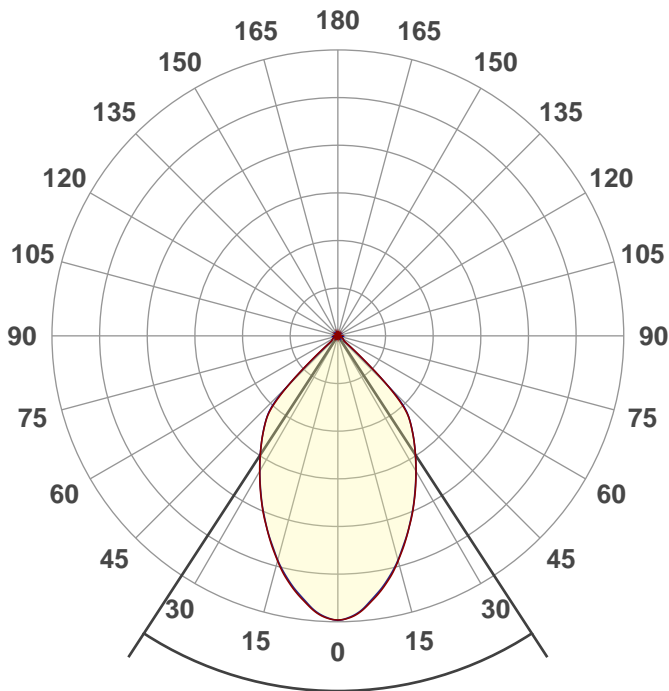

Beam angle
66,2°



CIE 1931
x: 0,375
y: 0,373

THD Values:

Voltage: 2,8%

Current: 9,55%

Spectra

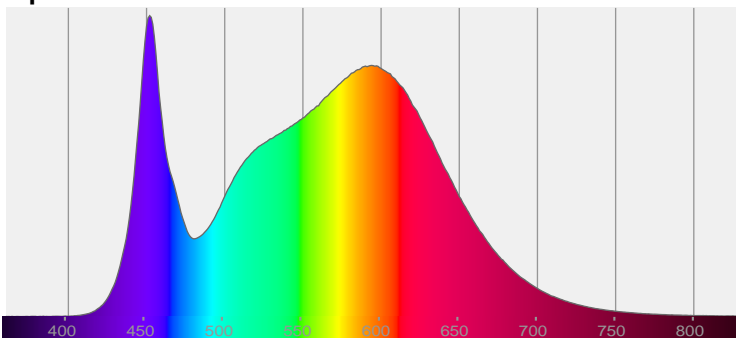

Power

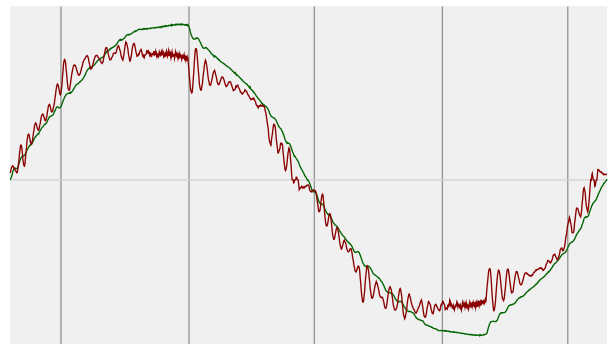

Voltage: 114 V
Current: 0,093 A
Frequency: 60 Hz

Color details

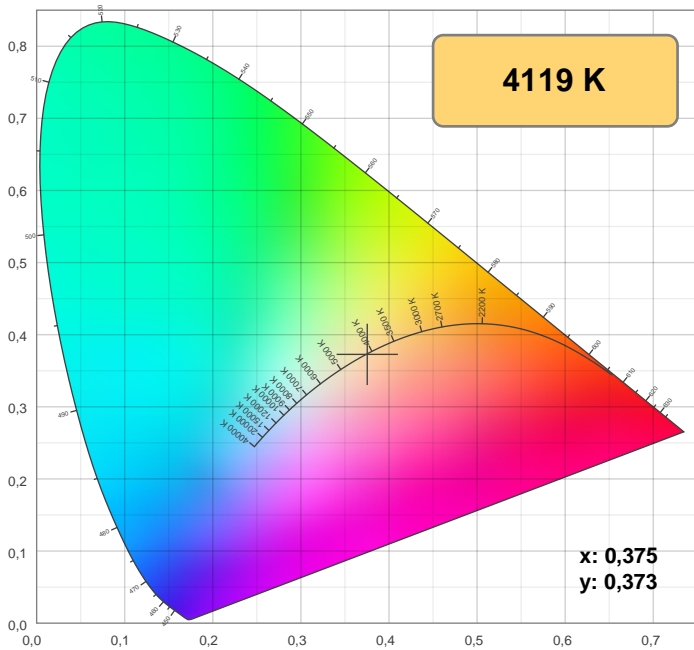

CIE 1931

CRI: 83,2 (R1-R8)

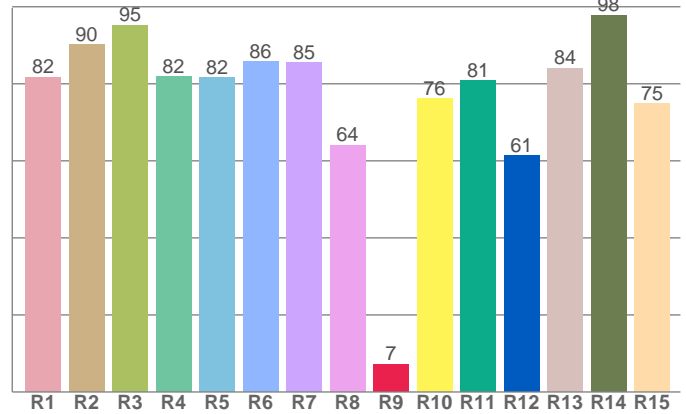

CRI R values, only R1-R8 are used to calculate final CRI value

R	R1	R2	R3	R4	R5	R6	R7	R8	9	R10	R11	R12	R13	R14	R15
Value	81,7	90,1	95,3	81,8	81,6	85,7	85,5	64,1	7,2	76,1	80,9	61,3	84,1	97,7	74,9

ISO Diagrams

ISO lux diagram

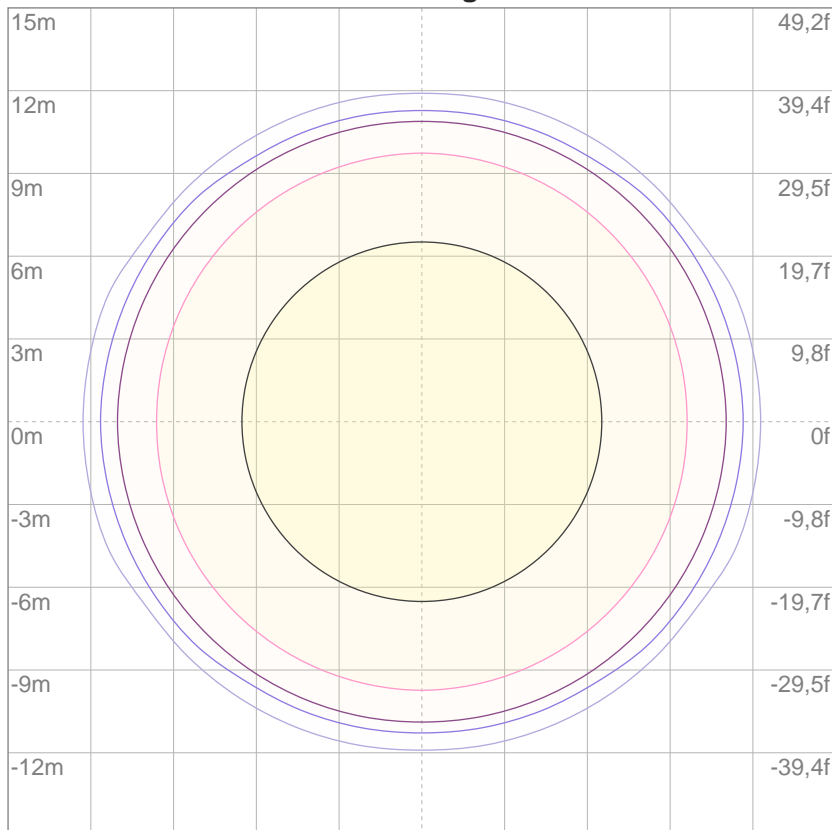

Mounting height: 10 meters (33 f)

3%	0,346 lx
5%	0,577 lx
10%	1,15 lx
30%	3,46 lx
50%	5,77 lx

Conditions:

Number of c-planes: 4

Lux at center: 11,5 lx

Lux distribution on a surface when lamp is mounted at 10 meters from the surface.

Beam details

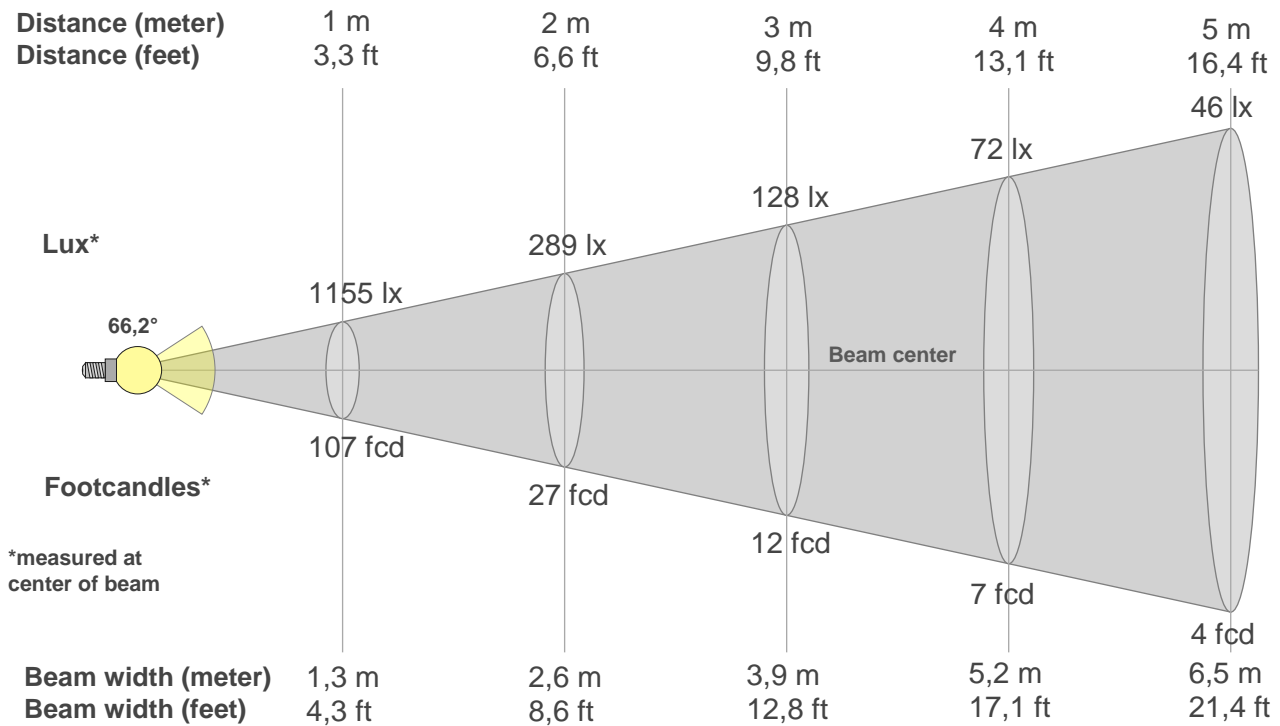

Beam intensities from 1-20m

1m	2m	3m	4m	5m	6m	7m	8m	9m	10m	11m	12m	13m	14m	15m	16m	17m	18m	19m	20m
3,3ft	6,6ft	9,8ft	13,1ft	16,4ft	19,7ft	23ft	26,2ft	29,5ft	32,8ft	36,1ft	39,4ft	42,7ft	45,9ft	49,2ft	52,5ft	55,8ft	59,1ft	62,3ft	65,6ft
1155lx	289lx	128lx	72lx	46lx	32lx	24lx	18lx	14lx	12lx	10lx	8lx	7lx	6lx	5lx	5lx	4lx	4lx	3lx	3lx
107,3fcd	26,8fcd	11,9fcd	6,7fcd	4,3fcd	3fcd	2,2fcd	1,7fcd	1,3fcd	1,1fcd	0,9fcd	0,7fcd	0,6fcd	0,5fcd	0,5fcd	0,4fcd	0,4fcd	0,3fcd	0,3fcd	0,3fcd

Intensities in 0° c-plane

0°	2°	4°	6°	8°	10°	12°	14°	16°	18°	20°	22°	24°	26°	28°	30°	32°	34°	36°	38°
1155	1149	1133	1107	1076	1044	1008	969	925	883	839	798	757	716	675	636	598	561	526	491
100%	100%	98%	96%	93%	90%	87%	84%	80%	76%	73%	69%	66%	62%	58%	55%	52%	49%	46%	43%

Intensities in 90° c-plane

0°	2°	4°	6°	8°	10°	12°	14°	16°	18°	20°	22°	24°	26°	28°	30°	32°	34°	36°	38°
1155	1147	1130	1102	1070	1038	1002	964	922	880	838	796	755	713	673	634	597	561	526	492
100%	99%	98%	95%	93%	90%	87%	84%	80%	76%	73%	69%	65%	62%	58%	55%	52%	49%	46%	43%

Intensities in 180° c-plane

0°	2°	4°	6°	8°	10°	12°	14°	16°	18°	20°	22°	24°	26°	28°	30°	32°	34°	36°	38°
1155	1149	1133	1107	1076	1044	1008	969	925	883	839	798	757	716	675	636	598	561	526	491
100%	100%	98%	96%	93%	90%	87%	84%	80%	76%	73%	69%	66%	62%	58%	55%	52%	49%	46%	43%

Intensities in 270° c-plane

0°	2°	4°	6°	8°	10°	12°	14°	16°	18°	20°	22°	24°	26°	28°	30°	32°	34°	36°	38°
1155	1147	1130	1102	1070	1038	1002	964	922	880	838	796	755	713	673	634	597	561	526	492
100%	99%	98%	95%	93%	90%	87%	84%	80%	76%	73%	69%	65%	62%	58%	55%	52%	49%	46%	43%

Beam angle 50%	Field angle 10%	Cutoff angle 2,5%	Intensity ratio in 120° cone	Intensity ratio in 90° cone
66,2°	95,4°	107,8°	97,6%	91,4%

TM30 details

Rf 81,8
Fidelity index Rf

Rg 94,8
Gammut index Rg

Hue Bin	R _f	Graphic shifts (%)	
		Chroma	Hue
1	77	-12%	0%
2	81	-7%	6%
3	76	-4%	11%
4	86	-1%	6%
5	89	0%	3%
6	94	1%	-2%
7	90	-5%	-2%
8	88	-6%	1%
9	84	-7%	8%
10	74	-6%	13%
11	75	3%	15%
12	83	6%	5%
13	84	8%	-8%
14	85	3%	-7%
15	74	-1%	-17%
16	74	-6%	-13%

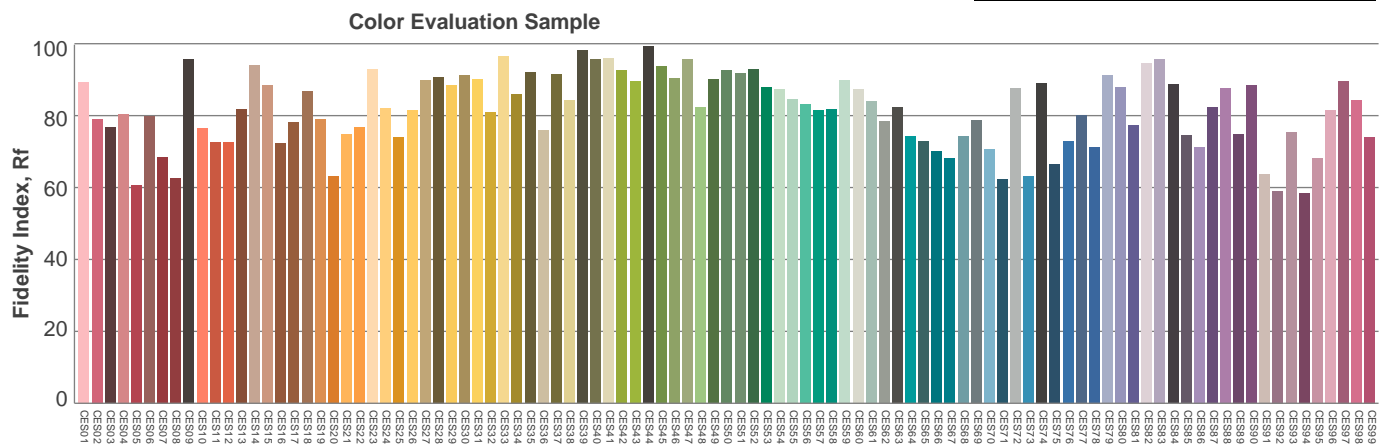
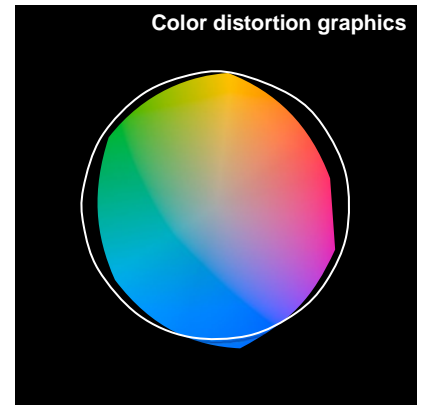
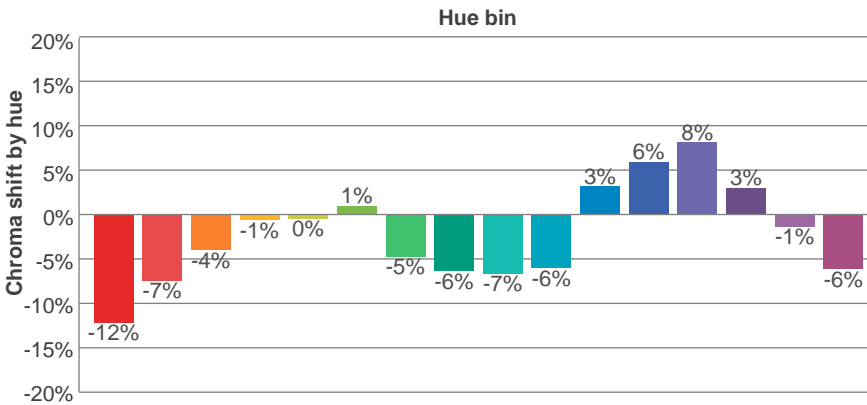
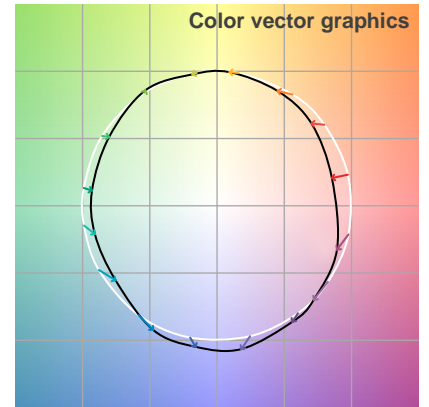
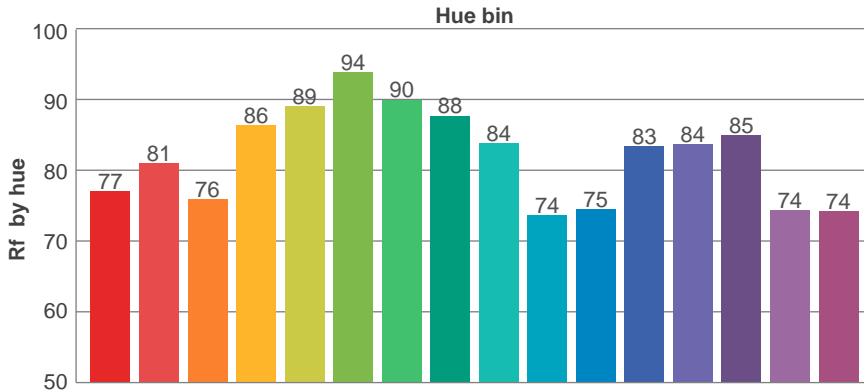
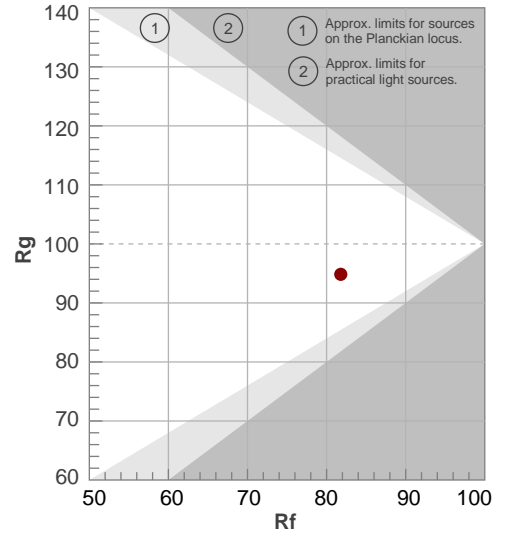

UGR

Glare Evaluation According to UGR

p Ceiling	70	70	50	50	30	70	70	50	50	30	
p Walls	50	30	50	30	30	50	30	50	30	30	
p Floor	20	20	20	20	20	20	20	20	20	20	
Room size X Y	Viewing direction at right angles to lamp axis					Viewing direction parallel to lamp axis					
2H	2H	21,4	22,3	21,7	22,5	22,7	21,4	22,2	21,7	22,4	22,6
	3H	21,4	22,1	21,7	22,4	22,6	21,3	22,1	21,6	22,3	22,6
	4H	21,4	22,1	21,7	22,3	22,6	21,3	22,0	21,7	22,3	22,6
	6H	21,4	22,0	21,7	22,3	22,6	21,4	22,0	21,7	22,3	22,6
	8H	21,4	22,0	21,7	22,3	22,6	21,4	22,0	21,7	22,3	22,6
	12H	21,4	21,9	21,7	22,2	22,6	21,3	21,9	21,7	22,2	22,5
4H	2H	21,3	22,0	21,6	22,2	22,5	21,2	21,9	21,5	22,2	22,5
	3H	21,2	21,8	21,6	22,1	22,5	21,2	21,8	21,6	22,1	22,4
	4H	21,3	21,8	21,7	22,1	22,5	21,3	21,8	21,6	22,1	22,5
	6H	21,3	21,8	21,8	22,1	22,5	21,3	21,8	21,7	22,1	22,5
	8H	21,4	21,8	21,8	22,1	22,5	21,4	21,7	21,8	22,1	22,5
	12H	21,4	21,7	21,8	22,1	22,5	21,3	21,7	21,8	22,1	22,5
8H	4H	21,2	21,6	21,7	22,0	22,4	21,2	21,6	21,6	22,0	22,4
	6H	21,3	21,7	21,8	22,1	22,5	21,3	21,6	21,8	22,1	22,5
	8H	21,4	21,7	21,9	22,1	22,6	21,4	21,6	21,8	22,1	22,6
	12H	21,4	21,6	21,9	22,1	22,6	21,4	21,6	21,9	22,1	22,6
12H	4H	21,2	21,6	21,6	22,0	22,4	21,2	21,5	21,6	21,9	22,4
	6H	21,3	21,6	21,8	22,0	22,5	21,3	21,6	21,8	22,0	22,5
	8H	21,4	21,6	21,9	22,1	22,6	21,4	21,6	21,9	22,1	22,5
Variation of the observer position for the luminaire distance S											
S = 1,0H	+2,3 / -5,2					+2,3 / -5,2					
S = 1,5H	+4,7 / -5,4					+4,7 / -5,4					
S = 2,0H	+6,6 / -5,9					+6,6 / -5,9					
Standard table	BK01					BK01					
Correction summand	3,4					3,4					
Corrected glare indices referring to 1303 lm total luminous flux											

Light planning

Coefficients of Utilization

Ceiling reflectance	80				70				50			30			10			0
Wall reflectance	70	50	30	10	70	50	30	10	50	30	10	50	30	10	50	30	10	0
Floor reflectance	20	20	20	20	20	20	20	20	20	20	20	20	20	20	20	20	20	0
RCR	(RCR: Room Cavity Ratio)																	
	Room Values are expressed as percentage of Lumens delivered to the task surface																	
0	119	119	119	119	116	116	116	116	111	111	111	106	106	106	102	102	102	100
1	113	109	107	104	110	107	105	102	103	101	99	99	98	96	96	95	93	92
2	106	101	96	92	104	99	95	91	95	92	89	92	90	87	90	87	85	83
3	100	92	87	82	98	91	86	82	88	84	80	86	82	79	84	80	78	76
4	94	85	79	74	92	84	78	74	82	77	73	80	75	72	78	74	71	69
5	88	79	72	67	87	78	72	67	76	71	66	74	69	66	73	68	65	64
6	83	73	66	61	82	72	66	61	71	65	61	69	64	60	68	63	60	58
7	78	68	61	56	77	67	61	56	66	60	56	65	59	56	63	59	55	54
8	74	63	57	52	73	63	56	52	62	56	52	60	55	51	59	55	51	50
9	70	59	53	48	69	59	52	48	58	52	48	57	51	48	56	51	47	46
10	66	55	49	45	65	55	49	45	54	48	44	53	48	44	52	48	44	43

LAMPS (number of lamps)

Luminaire budgetary diagram

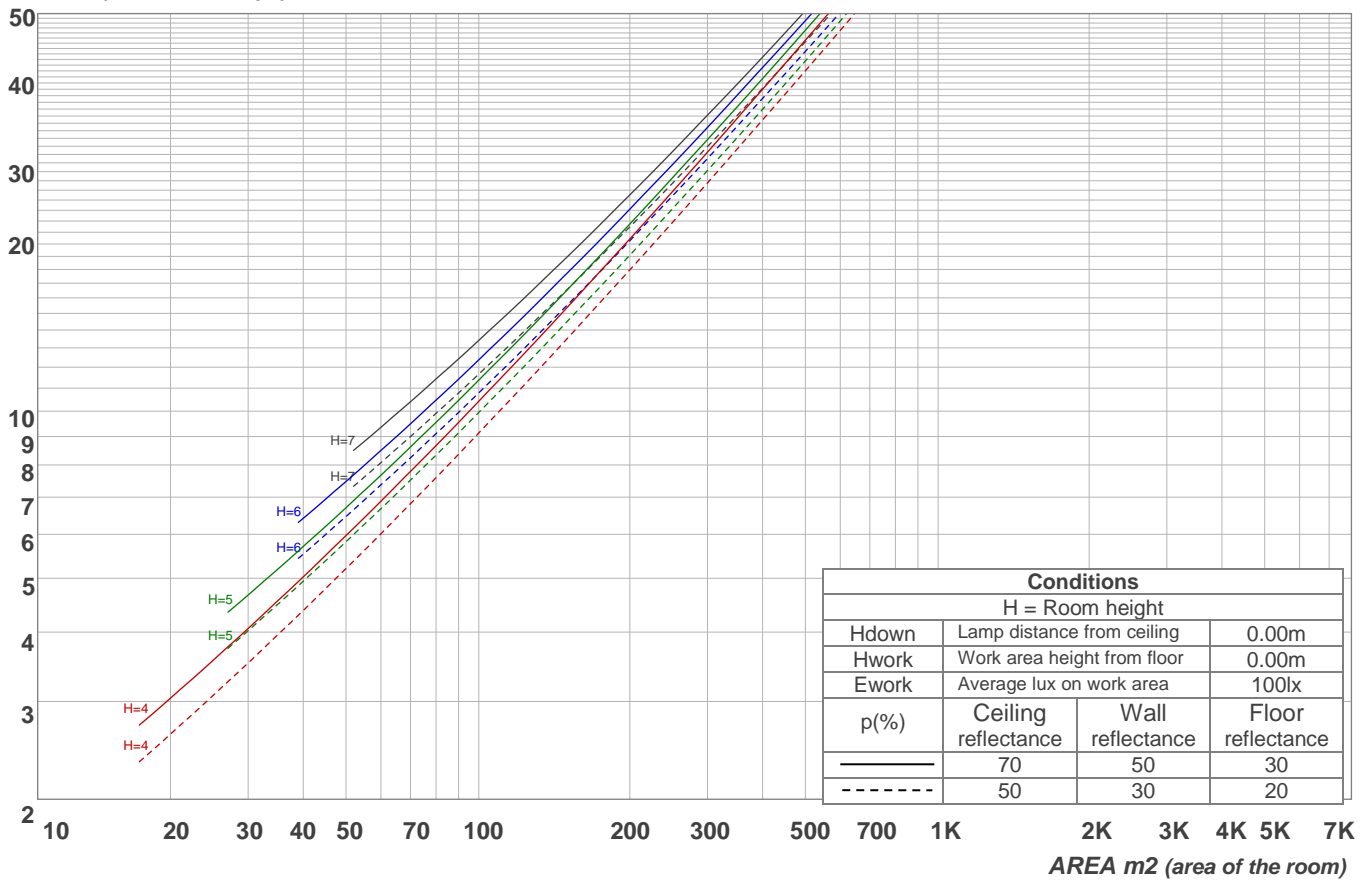

Zonal Lumen Summary

0°-10°	10°-20°	20°-30°	30°-40°	40°-50°	50°-60°	60°-70°	70°-80°	80°-90°
104 lm	264 lm	338 lm	340 lm	200 lm	25,2 lm	16,9 lm	11,0 lm	3,11 lm
90°-100°	100°-110°	110°-120°	120°-130°	130°-140°	140°-150°	150°-160°	160°-170°	170°-180°
0,076 lm	0,068 lm	0,080 lm	0,088 lm	0,097 lm	0,104 lm	0,085 lm	0,050 lm	0,015 lm

Stabilization

Warmup curve

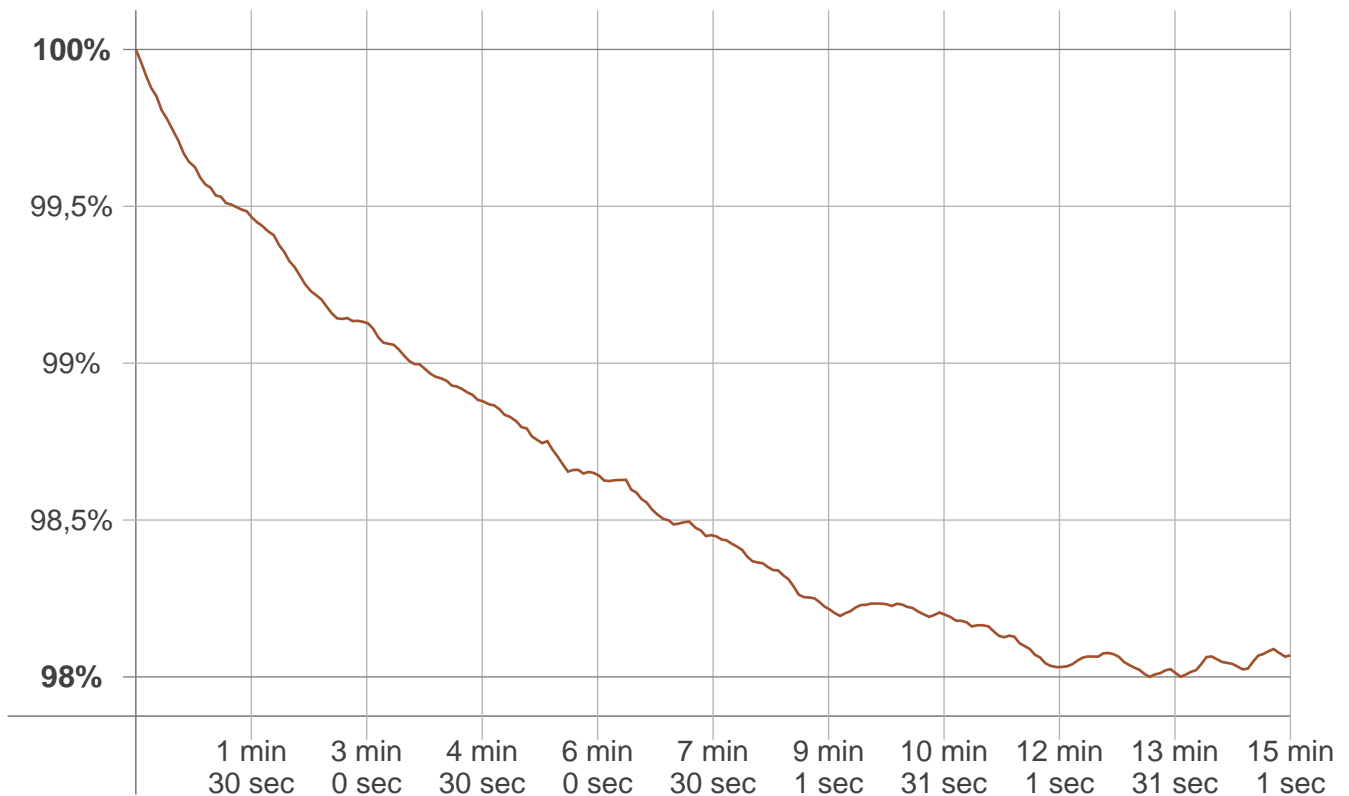

Warmup result

Warmup time:	15 min 1 sec
Warmup variation	-2,0%

Warmup conditions

Stable period:	15 min
Stable change max:	2,0%
Minimum time:	15 min

Color temperature change

CCT start	CCT change	CCT end
4103 K	+16 K	4119 K

Output change

Output start	Output change	Output end
1327 lm	-24 lm	1303 lm