

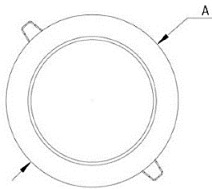

Dimensiones (mm)

A: Ø230
Altura: 2,9.



Corte: Ø210

Código

KT6617-LV-24W-4K

Descripción

Luminaria tipo bala, diseñada con módulo de LED integrado. Empotrada al techo por medio de sujetadores ubicados en los laterales. Compuesta por un difusor en acrílico opal.



Materiales y acabado

Sujetadores en hierro, recubiertos en plástico inyectado. Resortes en hierro con acabado galvanizado. Cuerpo y aro plástico inyectado.

Color

Blanco.

Características técnicas

LED	 116°	 50,000h	IP 20	IK 02
PF 0,98	THD <10%	°C 0-40	V 100-240	Hz 50/60

Fuente de luz

Bala con módulo de LED.

Potencia de Salida	CRI	K	Lm / W	Lm de Salida
22,4W	>80	4000	111	2485

Características de fuente de luz

- Color temperatura disponible 4000K (neutro).

Light efficiency:



Light quality:



Color temperature:



Output: 2485 lm

Peak: 841 cd

Power: 22,4 W

PF: 0,98



Product name:
E0654-KT6617-LV-24W-4K

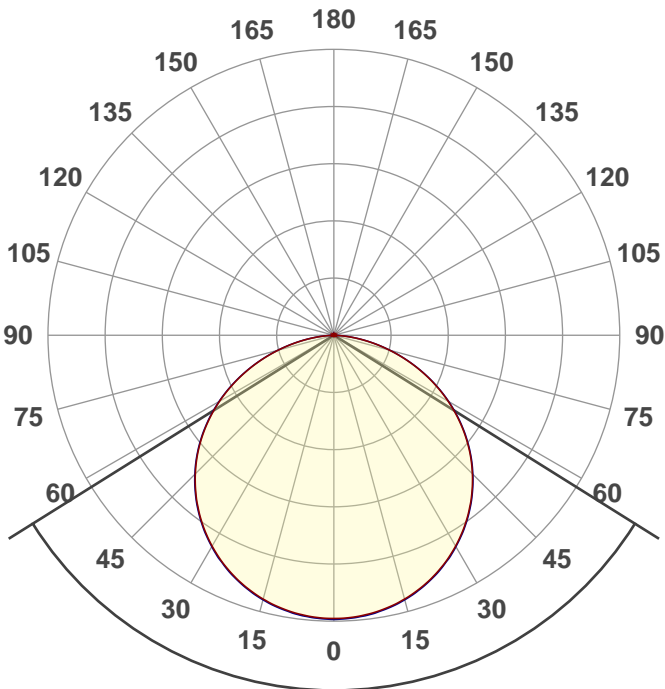

Beam angle **115,9°**



CIE 1931
x: 0,374
y: 0,375

THD Values:

Voltage: 2,4%

Current: 9,35%

Spectra

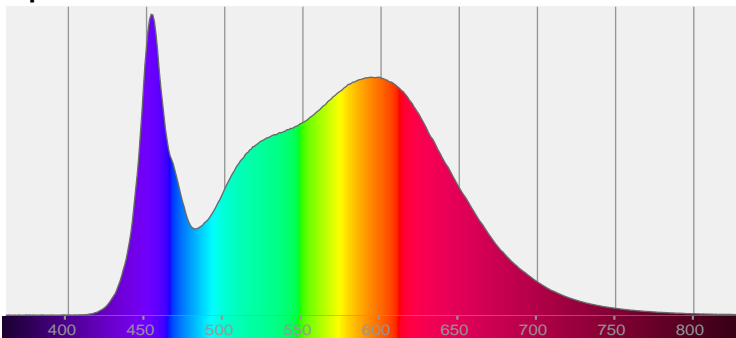

Power

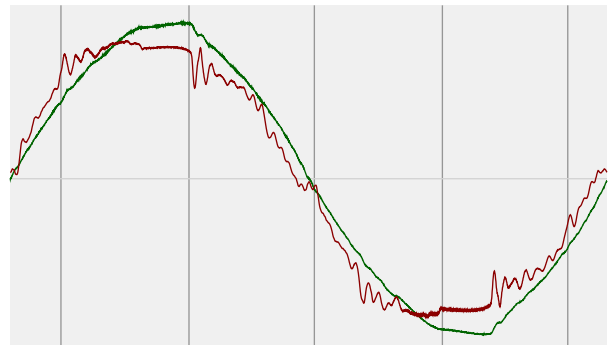

Voltage: 113 V
Current: 0,202 A
Frequency: 60,1 Hz

ISO Diagrams

ISO lux diagram

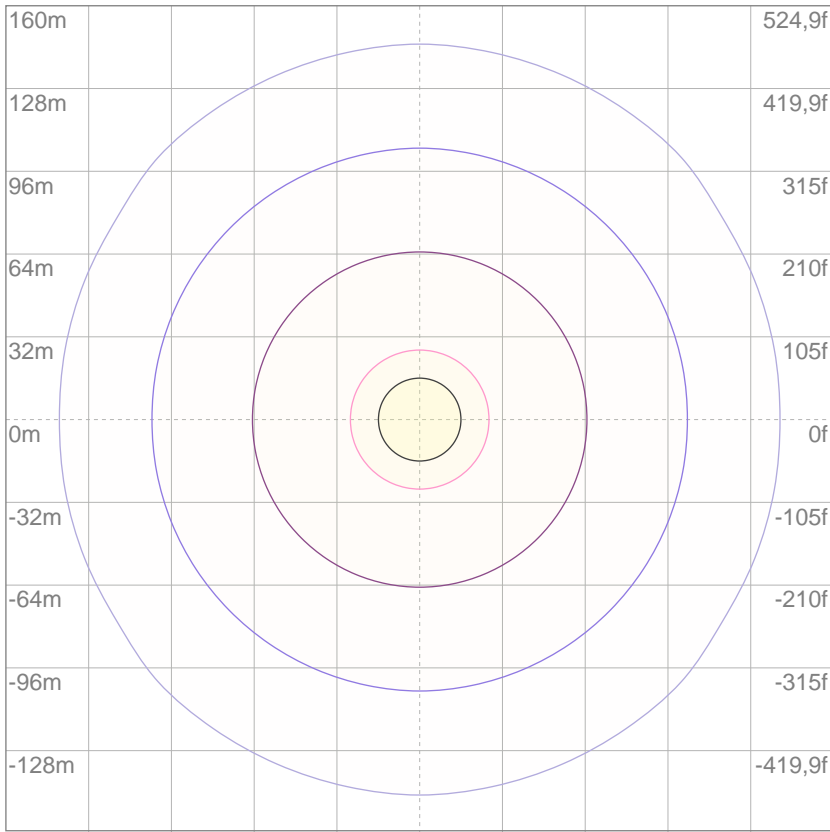

3%	0,252 lx
5%	0,420 lx
10%	0,840 lx
30%	2,52 lx
50%	4,20 lx

Conditions:
 Number of c-planes: 4
 Lux at center: 8,40 lx

Lux distribution on a surface when lamp is mounted at 10 meters from the surface.

Mounting height: 10 meters (33 f)

Color details

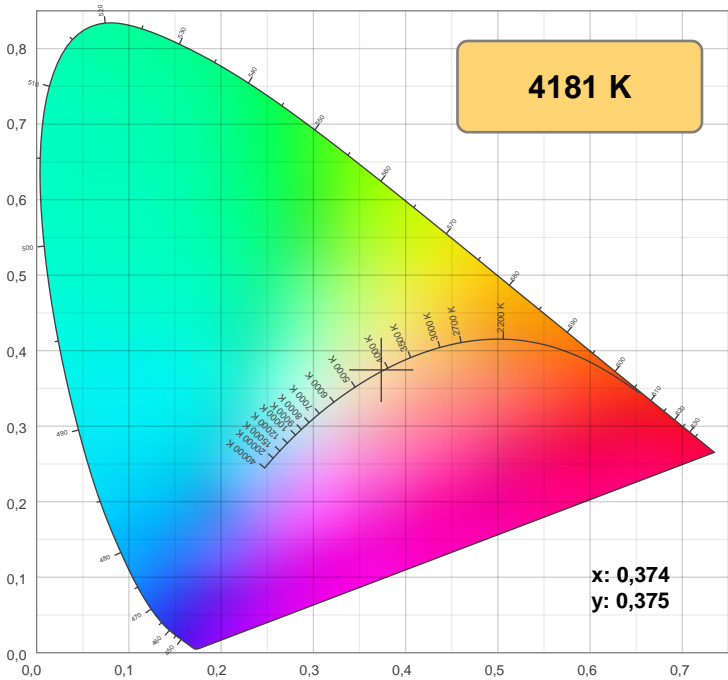

CIE 1931

CRI: 85,7 (R1-R8)

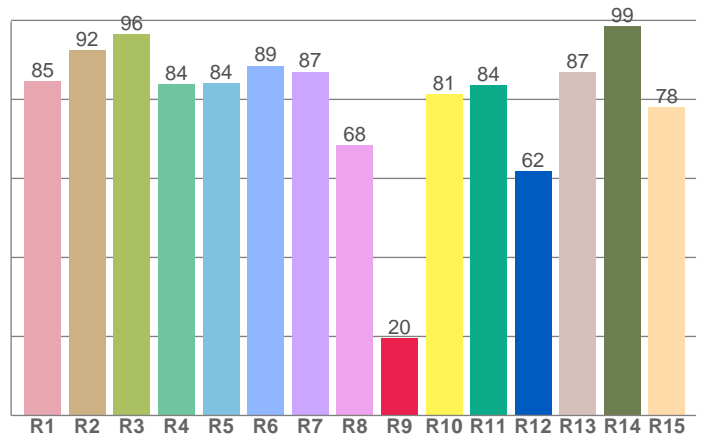

CRI R values, only R1-R8 are used to calculate final CRI value

R1	R2	R3	R4	R5	R6	R7	R8	R9	R10	R11	R12	R13	R14	R15
84,6	92,4	96,4	83,8	84,1	88,6	87,1	68,5	19,7	81,3	83,6	62,0	87,0	98,6	78,2

Color parameters

Color temperature	Color rendering index	Red component	Color fidelity	Color gamut	Color quality scale	Color coordinate cie 1931	Color coordinate cie 1931	Color coordinate	Color coordinate	Color deviation from black body
CCT	CRI	CRI R9	TM30 Rf	TM30 Rg	CQS	x	y	u	v	Δuv
4181 K	85,7	19,7	85,1	94,5	84,4	0,374	0,375	0,221	0,333	0,0010

TM-30 details

Rf 85,1
Fidelity index Rf

Rg 94,5
Gamut index Rg

Hue Bin	R _f	Shifts (%)	
		Chroma	Hue
1	81	-11%	0%
2	85	-6%	5%
3	83	-4%	8%
4	90	-2%	4%
5	91	-3%	2%
6	95	-1%	-1%
7	91	-6%	-1%
8	89	-6%	3%
9	85	-6%	9%
10	78	-4%	13%
11	80	4%	13%
12	88	6%	3%
13	86	7%	-9%
14	87	1%	-7%
15	78	-2%	-16%
16	78	-6%	-11%

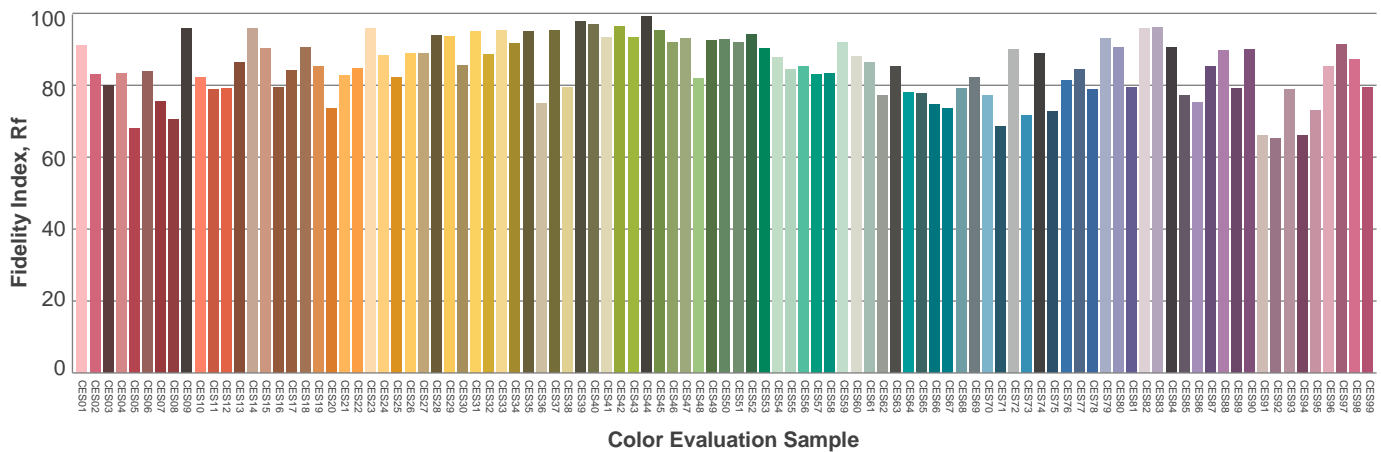
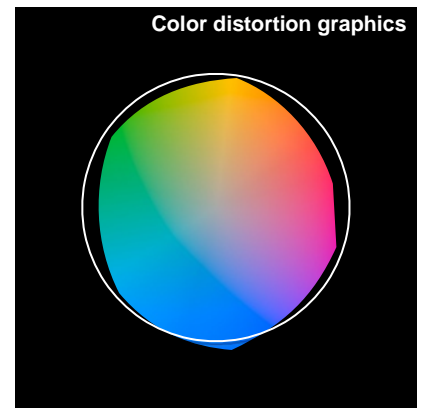
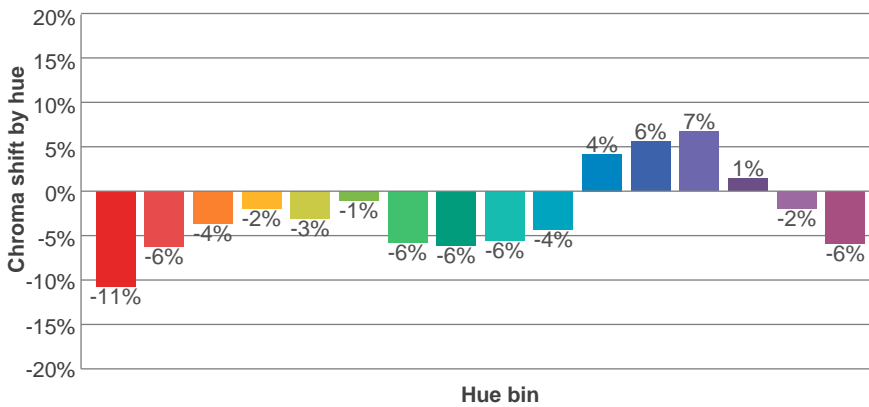
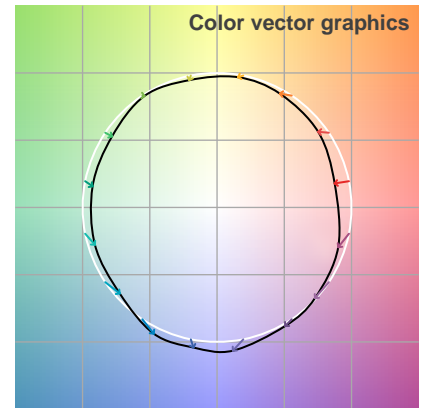
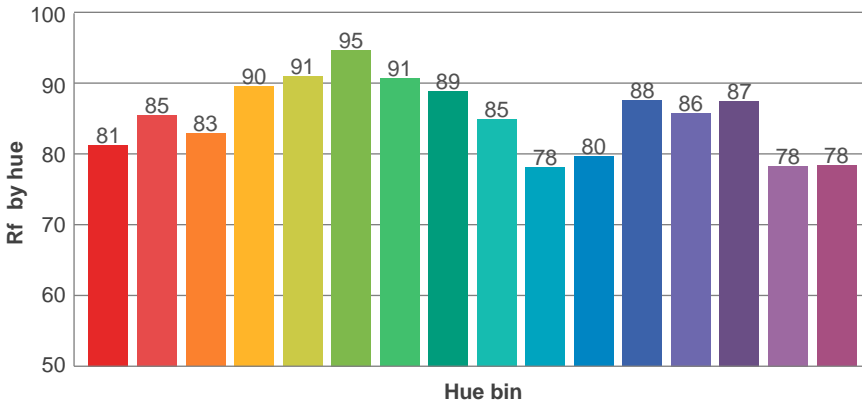
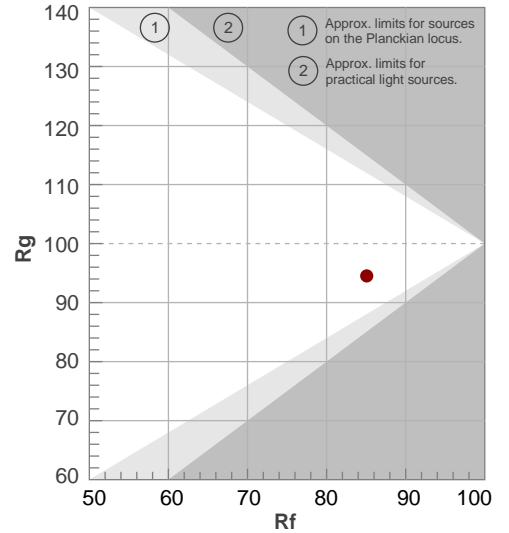

Beam details

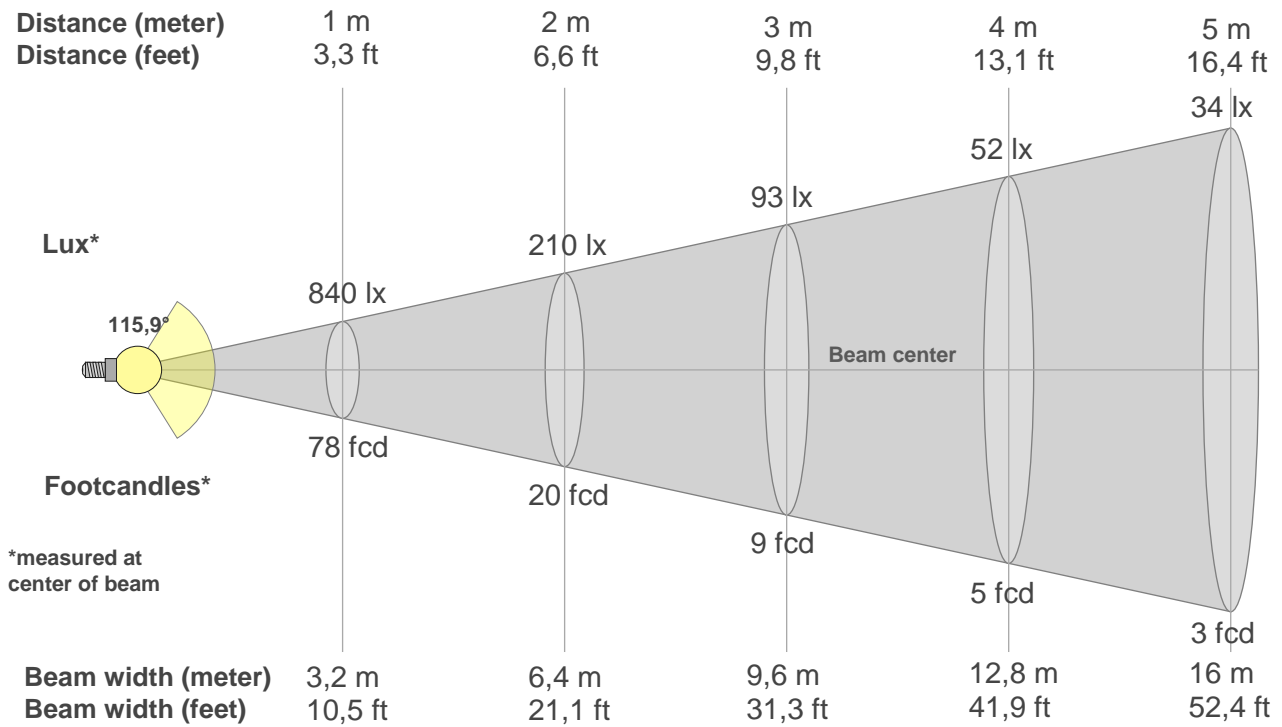

Beam intensities from 1-20m

{BEAM_INT_TABLE_START}

m	m	m	m	m	m	m	m	m	m	m	m	m	m	m	m	m	m	m	m	m
ft	ft	ft	ft	ft	ft	ft	ft	ft	ft	ft	ft	ft	ft	ft	ft	ft	ft	ft	ft	ft
lx	lx	lx	lx	lx	lx	lx	lx	lx	lx	lx	lx	lx	lx	lx	lx	lx	lx	lx	lx	lx
fcd	fcd	fcd	fcd	fcd	fcd	fcd	fcd	fcd	fcd	fcd	fcd	fcd	fcd	fcd	fcd	fcd	fcd	fcd	fcd	fcd

Intensities in 0° c-plane

0°	5°	10°	15°	20°	25°	30°	35°	40°	45°	50°	55°	60°	65°	70°	75°	80°	85°	90°	95°
840	835	825	808	785	756	721	679	633	580	522	459	391	319	245	171	100	36	1	0
100%	99%	98%	96%	94%	90%	86%	81%	75%	69%	62%	55%	47%	38%	29%	20%	12%	4%	0%	0%

Intensities in 90° c-plane

0°	5°	10°	15°	20°	25°	30°	35°	40°	45°	50°	55°	60°	65°	70°	75°	80°	85°	90°	95°
840	837	827	811	788	758	723	681	634	582	524	461	392	320	246	171	100	37	1	0
100%	100%	98%	97%	94%	90%	86%	81%	76%	69%	62%	55%	47%	38%	29%	20%	12%	4%	0%	0%

Intensities in 180° c-plane

0°	5°	10°	15°	20°	25°	30°	35°	40°	45°	50°	55°	60°	65°	70°	75°	80°	85°	90°	95°
840	835	825	808	785	756	721	679	633	580	522	459	391	319	245	171	100	36	1	0
100%	99%	98%	96%	94%	90%	86%	81%	75%	69%	62%	55%	47%	38%	29%	20%	12%	4%	0%	0%

Intensities in 270° c-plane

0°	5°	10°	15°	20°	25°	30°	35°	40°	45°	50°	55°	60°	65°	70°	75°	80°	85°	90°	95°
840	837	827	811	788	758	723	681	634	582	524	461	392	320	246	171	100	37	1	0
100%	100%	98%	97%	94%	90%	86%	81%	76%	69%	62%	55%	47%	38%	29%	20%	12%	4%	0%	0%

Beam angle 50%	Field angle 10%	Cutoff angle 2,5%	Intensity ratio in 120° cone	Intensity ratio in 90° cone
115,9°	162,4°	172,8°	78,1%	52,6%

UGR

Glare Evaluation According to UGR

p Ceiling	70	70	50	50	30	70	70	50	50	30	
p Walls	50	30	50	30	30	50	30	50	30	30	
p Floor	20	20	20	20	20	20	20	20	20	20	
Room size X Y	Viewing direction at right angles to lamp axis					Viewing direction parallel to lamp axis					
2H	2H	23,0	24,2	23,2	24,5	24,7	23,0	24,2	23,2	24,5	24,8
	3H	24,5	25,8	24,9	26,0	26,2	24,5	25,8	24,9	26,1	26,3
	4H	25,1	26,3	25,5	26,6	26,9	25,1	26,4	25,5	26,6	26,9
	6H	25,6	26,7	25,9	27,0	27,4	25,7	26,7	26,0	27,0	27,4
	8H	25,8	26,8	26,1	27,1	27,5	25,8	26,8	26,1	27,1	27,5
4H	12H	25,8	26,8	26,2	27,1	27,6	25,8	26,8	26,2	27,2	27,6
	2H	23,6	24,8	24,0	25,1	25,4	23,6	24,8	24,0	25,1	25,4
	3H	25,4	26,4	25,8	26,8	27,2	25,4	26,4	25,8	26,8	27,2
	4H	26,1	27,0	26,5	27,4	28,0	26,1	27,0	26,6	27,5	28,0
	6H	26,7	27,6	27,2	27,9	28,3	26,7	27,6	27,2	27,9	28,3
8H	8H	26,8	27,6	27,3	28,0	28,4	26,9	27,7	27,4	28,0	28,4
	12H	26,9	27,6	27,4	28,0	28,5	26,9	27,6	27,4	28,0	28,5
	4H	26,4	27,2	26,9	27,6	28,0	26,4	27,2	26,9	27,6	28,0
	6H	27,1	27,7	27,6	28,2	28,7	27,1	27,7	27,6	28,2	28,8
	8H	27,4	27,9	27,9	28,4	29,1	27,4	27,9	27,9	28,5	29,1
12H	12H	27,5	28,0	28,1	28,5	29,1	27,5	28,0	28,1	28,5	29,1
	4H	26,4	27,1	26,9	27,5	28,0	26,4	27,1	26,9	27,5	28,0
	6H	27,2	27,7	27,7	28,2	28,9	27,2	27,7	27,7	28,3	28,9
8H	27,5	27,9	28,0	28,4	29,0	27,5	27,9	28,1	28,4	29,1	
Variation of the observer position for the luminaire distance S											
S = 1.0H	0,1 / -0,1					0,1 / -0,1					
S = 1.5H	0,1 / -0,2					0,1 / -0,2					
S = 2.0H	0,4 / -0,5					0,4 / -0,5					
Standard table	n/a					n/a					
Correction summand	n/a					n/a					
Corrected glare indices referring to 2485 lm total luminous flux											

Light planning

Coefficients of Utilization

Ceiling reflectance	80				70				50			30			10			0			
Wall reflectance	70	50	30	10	70	50	30	10	50	30	10	50	30	10	50	30	10	0			
Floor reflectance	20	20	20	20	20	20	20	20	20	20	20	20	20	20	20	20	20	20	20	20	0
RCR	(RCR: Room Cavity Ratio)																				
	Room Values are expressed as percentage of Lumens delivered to the task surface																				
0	119	119	119	119	116	116	116	116	111	111	111	106	106	106	102	102	102	100			
1	109	104	99	95	106	101	98	94	97	94	91	93	91	88	90	87	85	83			
2	99	90	83	77	96	88	82	76	85	79	75	81	77	73	78	75	71	69			
3	90	79	71	64	87	77	70	63	74	68	62	72	66	61	69	64	60	58			
4	82	70	61	54	80	68	60	54	66	59	53	64	57	52	61	56	51	49			
5	75	62	53	46	73	61	53	46	59	51	46	57	50	45	55	49	45	42			
6	69	56	47	40	68	55	46	40	53	46	40	51	45	39	50	44	39	37			
7	64	51	42	36	63	50	41	35	48	41	35	47	40	35	45	39	35	33			
8	60	46	38	32	58	45	37	32	44	37	31	43	36	31	42	36	31	29			
9	56	42	34	28	54	42	34	28	41	33	28	39	33	28	38	32	28	26			
10	52	39	31	26	51	39	31	26	38	30	26	37	30	25	36	30	25	24			

LAMPS (number of lamps)

Luminaire budgetary diagram

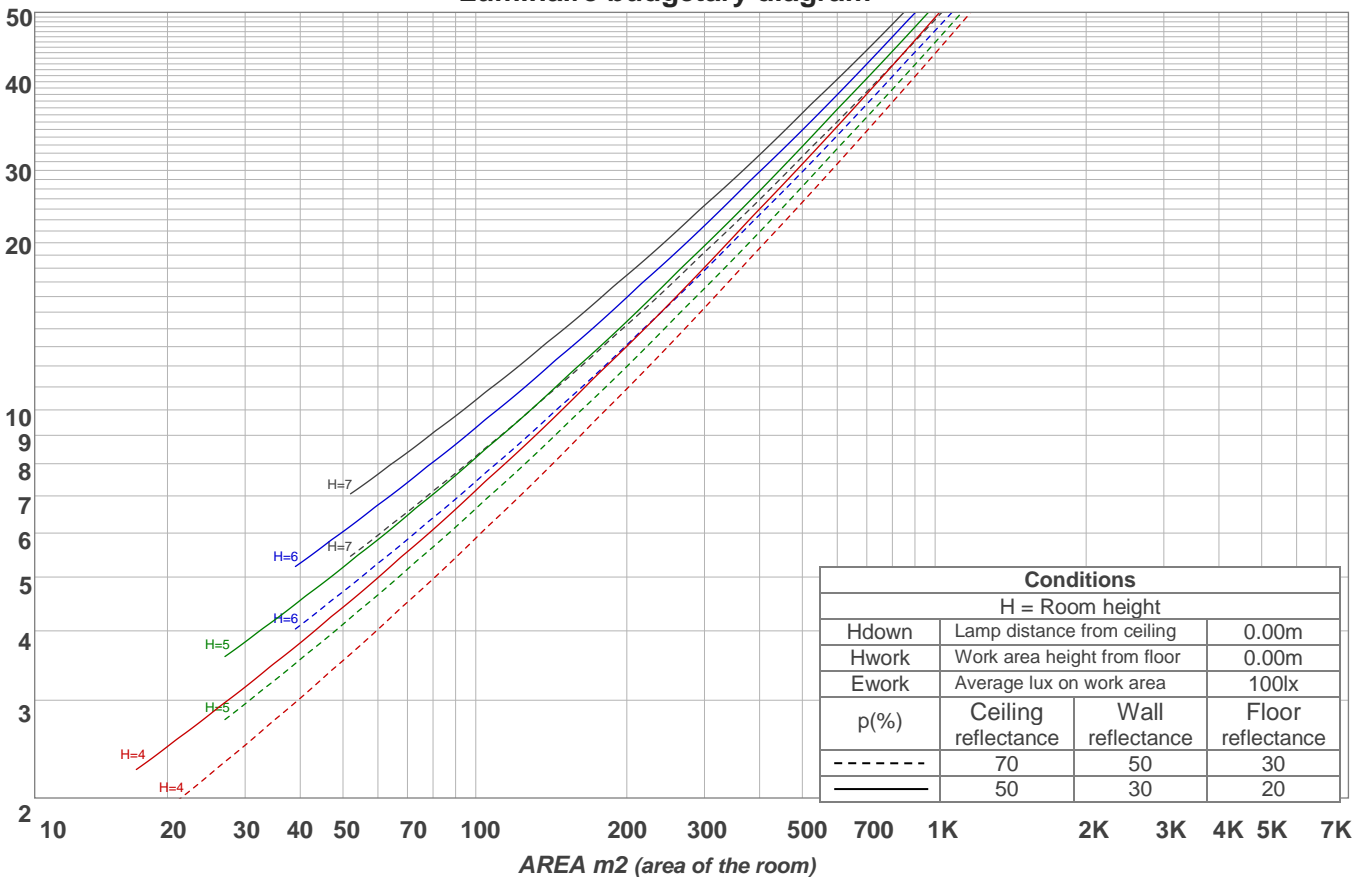

Zonal Lumen Summary

0°-10°	10°-20°	20°-30°	30°-40°	40°-50°	50°-60°	60°-70°	70°-80°	80°-90°
79,5 lm	229 lm	349 lm	426 lm	448 lm	411 lm	316 lm	181 lm	44,0 lm
90°-100°	100°-110°	110°-120°	120°-130°	130°-140°	140°-150°	150°-160°	160°-170°	170°-180°
0,227 lm	0,301 lm	0,379 lm	0,431 lm	0,435 lm	0,400 lm	0,320 lm	0,208 lm	0,075 lm

Stabilization

Warmup curve

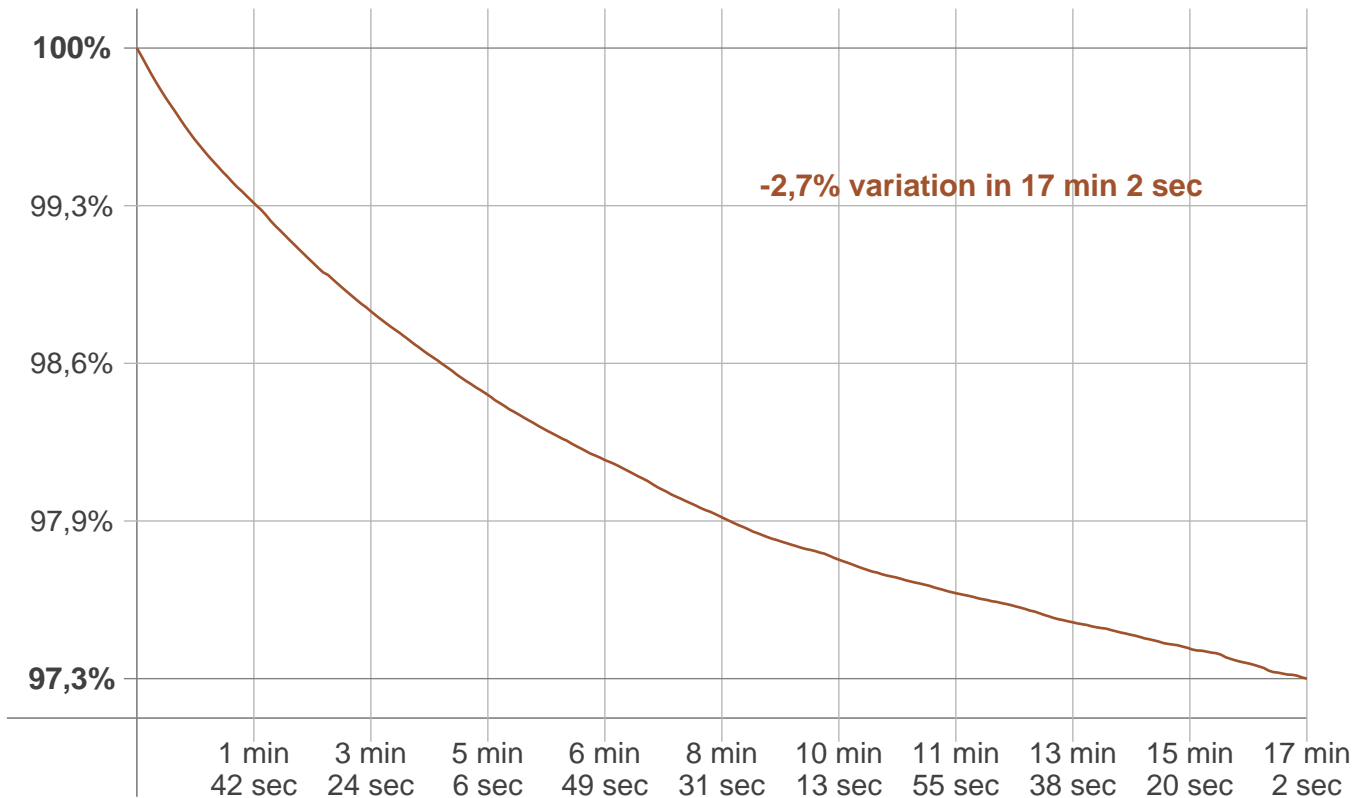

Warmup result

Warmup time:	17 min 2 sec
Warmup variation	-2,7%

Warmup conditions

Stable period:	15 min
Stable change max:	2,0%
Minimum time:	15 min

Color temperature change

CCT start	CCT change	CCT end
4133 K	+48 K	4181 K

Output change

Output start	Output change	Output end
2552 lm	-67 lm	2485 lm