

PHILIPS ADVANCE

LED Driver

Xitanium

Xitanium 75W 0.1-2.0A 0-10V with SimpleSet XI075C200V054BPT1

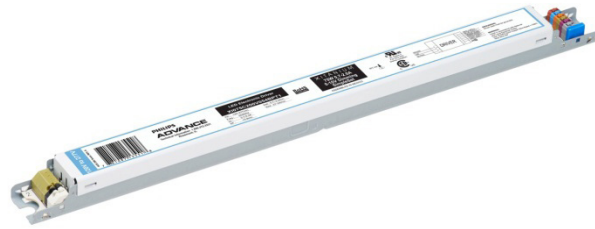

Philips Advance Xitanium Linear LED Drivers with SimpleSet technology are designed to give OEMs ultimate flexibility. With wide operating windows, slim profile and simple programming, luminaire manufacturers can design luminaires of different sizes and lumen levels for office and retail applications.

Specifications

Input Voltage (Vrms)	Output Power (W)	Output Voltage (V)	Output Current (A)	Efficiency @ Max Load	Max. Case Temp. (°C)	Input Current (Arms)	Max. Input Power (W)	Inrush Current (A _{pk} /10%- μ s)	THD @ Max. Load	Power Factor @ Max. Load	Surge Protection Ring wave (KV)	Weight (Lbs/kgs)	Envir. Protection Rating
120	75	27 ~ 54	0.1 – 2.0	87.5%	Life 80 °C UL 85 °C	0.7	84	34 / 118	<10%	>0.95	>2.5	0.79/ 0.36	UL Dry & Damp
277				89.5%		0.3		64 / 115	<15%				

Enclosure

	In. (mm)
Case Length	16.6 (424)
Case Width	1.18 (30)
Case Height	1.0 (25.4)
Mounting Length	16.3 (415)
Overall Length	16.6 (424)

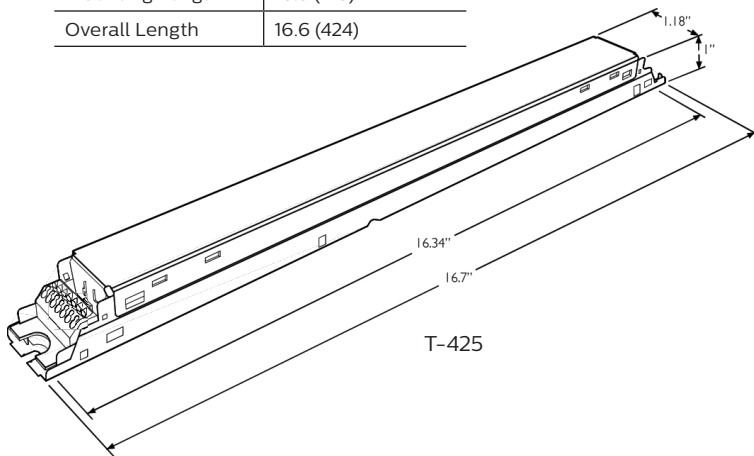

Wiring Diagram

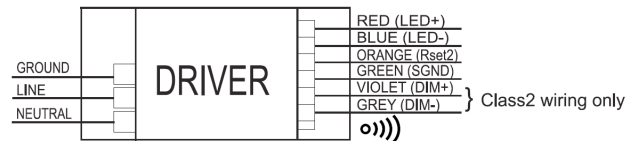

Driver case must be grounded.

Install in accordance with National and Local Electrical Codes.

Connect wires:

Use 18 AWG Solid Copper Wire

Rated \geq 300V/85°C.

Strip Wire 3/8".

Dimming Method	Dimming Range	Minimum Output Current (A)	Other Comments
0-10V Class 2 Wiring	5% ~ 100% (for output current range 0.7-2.0A)	0.035	Dimming source current: 150 μ A

UL Conditions of Acceptability:

Please contact your Philips representative for a copy of the latest UL Conditions of Acceptability (COA).

Xitanium 75W 0.1-2.0A 54V 0-10V with SimpleSet

Features

- Programmable output current through SimpleSet
- Large operating window, with max current of 2A
- Slim linear form factor

Benefits

- Fast and simple way of programming
- Enables fixture designs with wide variety of loads and current
- Enables easy integration into narrow fixtures and troffers

Application

- Indoor linear applications such as troffers and pendants
- Office
- Retail
- Low bay

Product Data

Ordering Information	
Order Code	XI075C200V054BPT1
Full Product Code	XI075C200V054BPT1M (Mid-Pack, 12pcs/box)
Full Product Name	XITANIUM 75W 0.1-2.0A 54V 0-10V INT-T
Input Information	
Line Voltage	120-277Vac_rms
Line Current	0.70A @ 120V, 0.30A @ 277V
Line Frequency	50/60Hz
Min. Mains Voltage Operational	108 V [min]
Max. Mains Voltage Operational	305V [max]
THD (total)	Refer to graph
Power Factor (PF)	Refer to graph
Inrush Current	Per NEMA 410
Lightning Surge Protection	Refer to table below
Output Information	
Output Voltage Range	27V to 54Vdc
Maximum Open Circuit Voltage	60V
Output Current Ripple (ripple = peak to average / average)	15% max @ max Iout Low frequency (≤ 120 Hz) content <5%
Protections	Short Circuit and Open Circuit Protection for LED + and LED-, miss-wiring protection
Ambient Temp Range	-20C to +50C
Max Case Temperature (Tcase)	80°C for Life & 85°C for UL Safety
Features	
Interfaces	0-10V Dimming, AOC
AOC (Adjustable Output Current)	100mA to 2000mA via external resistor or SimpleSet programming (refer to graph and notes below)
MTP (Module Temperature Protection)	N/A
0-10V Dimming Specifications	150 μ A source current from driver. See dim curve for detail.
Environment & Approbation	
Environmental Protection Rating	UL damp and dry
Agency Approbations	UL8750, UL1310, UL935, CSA-C22.2 No. 250.13-12, CSA C22.2 No. 223
Electromagnetic Compliance	FCC Title 47 Part 15 Class A
Isolation	Refer to table
Audible Noise	<24dB Class A

Xitanium 75W 0.1-2.0A 54V 0-10V with SimpleSet

Electrical Specifications

All the specifications are typical and at 25°C Tcase unless specified otherwise.

0-10V Dimming Curve:

Dimming source current from the driver: 150µA (@ 0<Vdim<8V)

LED Current Tolerance at 2000mA ≤ 5% over temperature and component variations

Minimum Dim Level: 5% of Iout (minimum 35mA)

Maximum output voltage on the dimming wires: 12V

Approved Dimmer List

Manufacturer	Manufacturer Part Number
Lutron	Visit www.lutron.com/advance for a list of dimmers (Mark VII) that will work with this driver
Leviton	IllumaTech IP7 series
Philips	Sunrise - SR1200ZTUNV

For compatibility with other dimmers please contact the dimmer manufacturer.

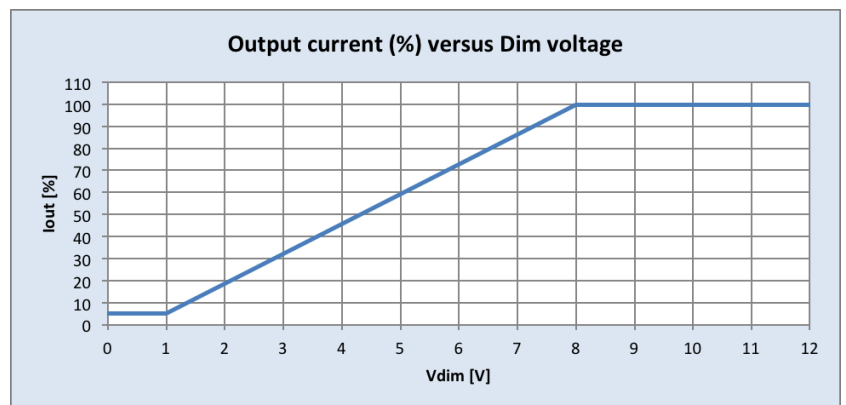

Xitanium 75W 0.1-2.0A 54V 0-10V with SimpleSet

Electrical Specifications

All the specifications are typical and at 25°C Tcase unless specified otherwise.

Adjustable Output Current (AOC) Info:

LED Current Tolerance over temperature and component variations for AOC \leq 10% at any level.

Rset (Ohms)	Current (mA)	Rset (Ohms)	Current (mA)
1	100	1800	684
100	100	2000	733
110	106	2200	780
120	111	2400	823
130	116	2700	883
150	125	3000	941
160	130	3300	993
180	138	3600	1042
200	146	3900	1085
220	155	4300	1143
240	166	4700	1192
270	176	5100	1238
300	190	5600	1293
330	204	6200	1350
360	215	6800	1402
390	228	7500	1454
430	245	8200	1503
470	261	9100	1558
510	277	10000	1604
560	300	11000	1653
620	318	12000	1694
680	340	13000	1730
750	368	15000	1793
820	392	16000	1817
910	422	18000	1864
1000	452	20000	1902
1100	485	22000	1934
1200	515	24000	1965
1300	545	27000	2000
1500	602	36000	2000
1600	632	>100000	2000

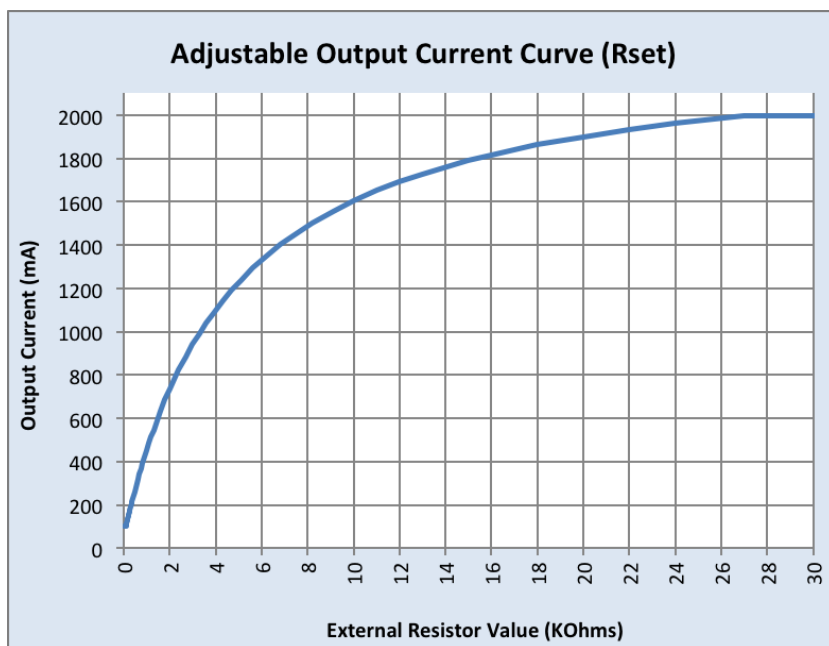

Notes:

1. There are two ways to adjust the current.
 - a. Using a resistor between Rset2 & SGND leads
 - i. Any through hole or SMD resistor with >0.25W and >20V can be used as RSET between Rset and SGND pins.
 - ii. Driver will default to 2000mA when Rset is left open.
 - b. Using SimpleSet programming
(Visit www.philips.com/simpleset for details.)
2. The driver is by default set to Rset2.

Xitanium 75W 0.1-2.0A 54V 0-10V with SimpleSet

Electrical Specifications

All the specifications are typical and at 25°C Tcase unless specified otherwise.

Operating Window:

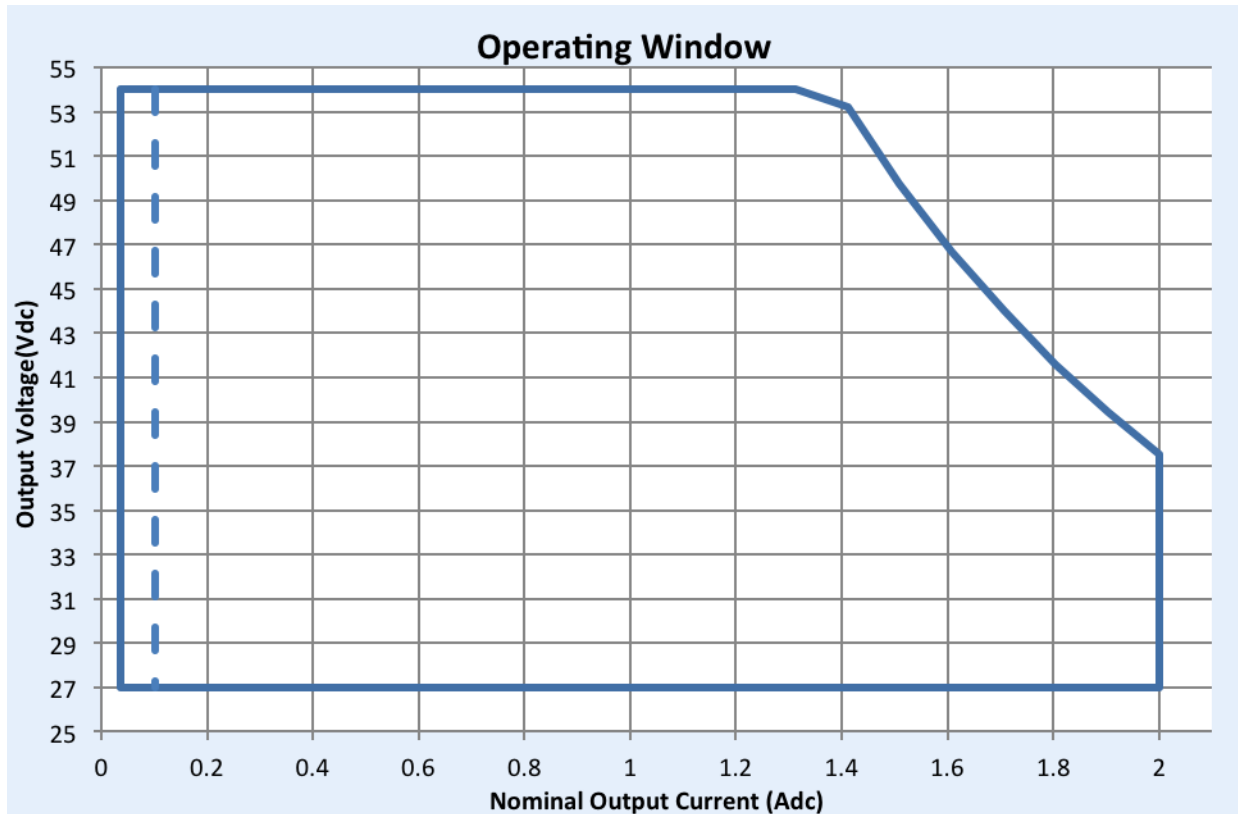

Note:

For 5% dimming output current setting through AOC should be >0.7A

Xitanium 75W 0.1-2.0A 54V 0-10V with SimpleSet

Performance Characteristics

Based on measurements on a typical sample. The accuracy of the measurements is within the tolerance of the measurement instruments. The graphs are meant to be a guideline and not a specification.

Performance Plots:

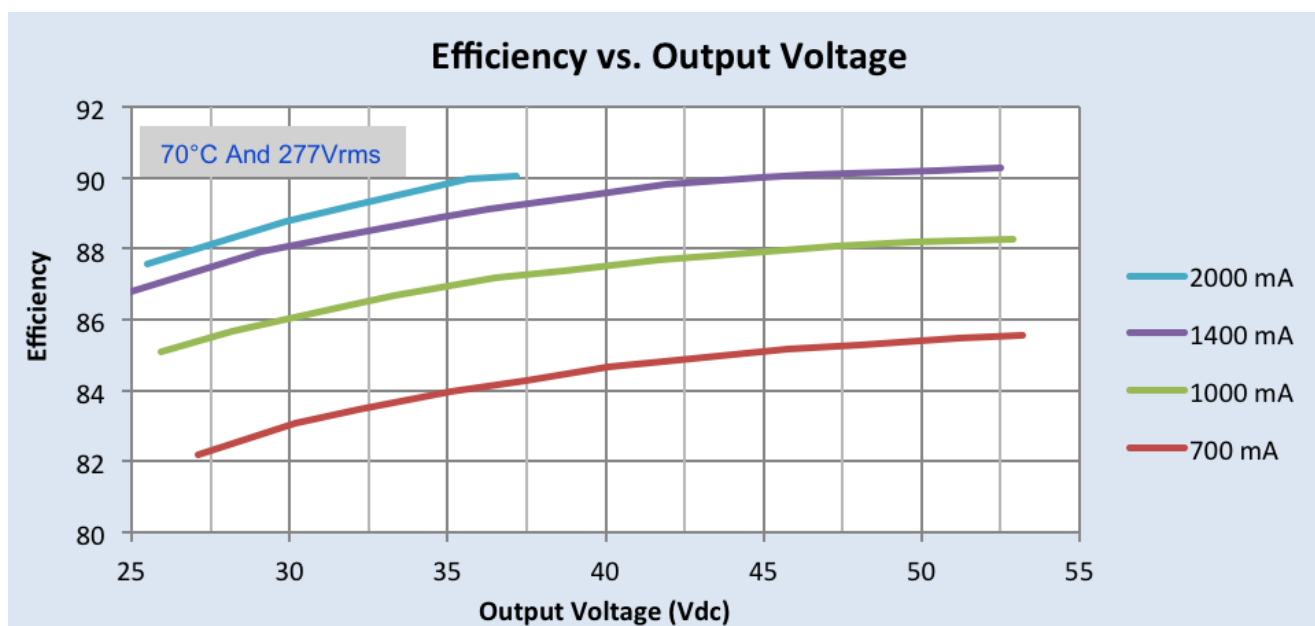
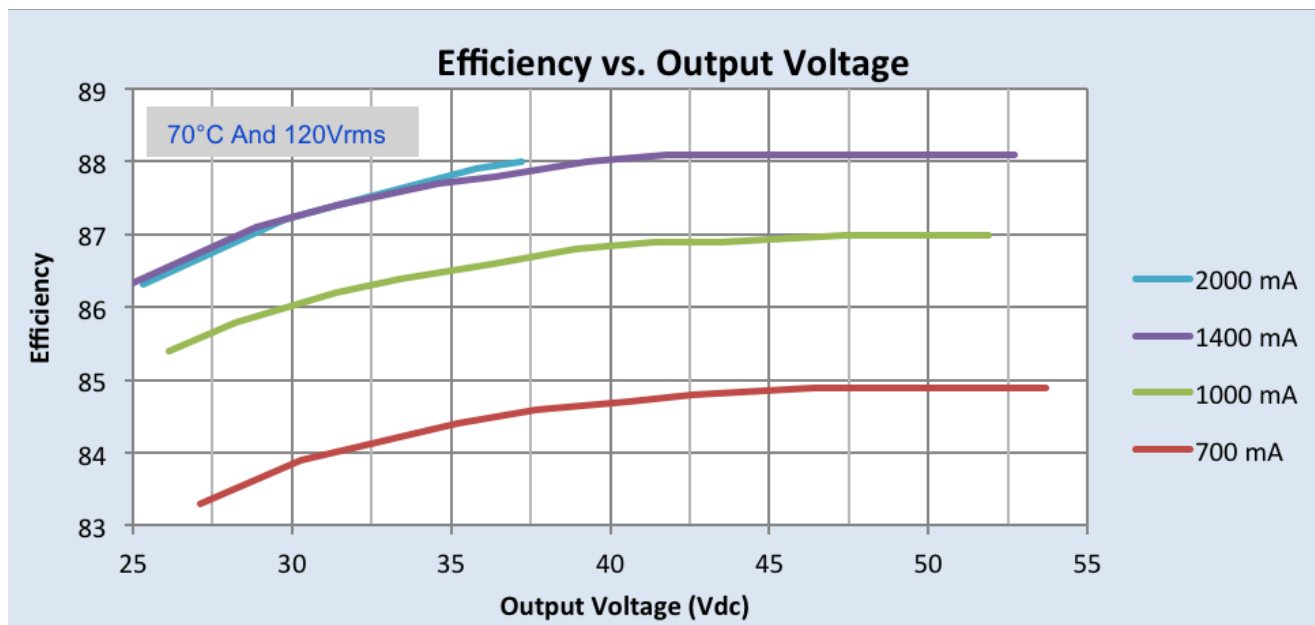

Xitanium 75W 0.1-2.0A 54V 0-10V with SimpleSet

Performance Characteristics

Based on measurements on a typical sample. The accuracy of the measurements is within the tolerance of the measurement instruments. The graphs are meant to be a guideline and not a specification.

Power Factor vs. Output Power:

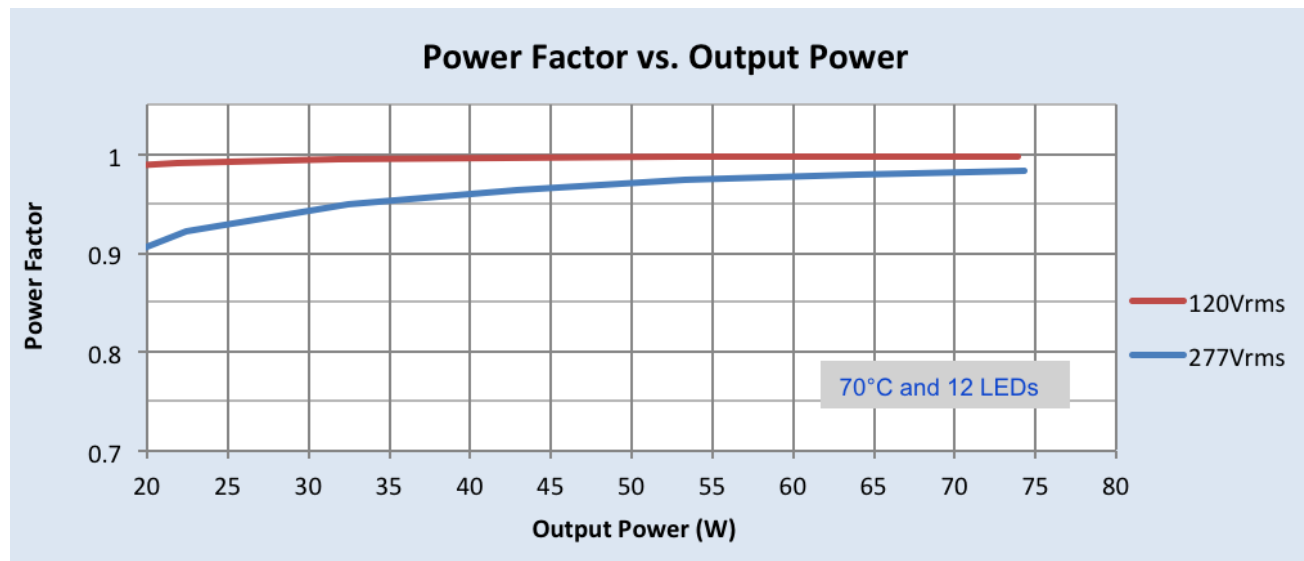

Total Harmonic Distortion vs. Output Power:

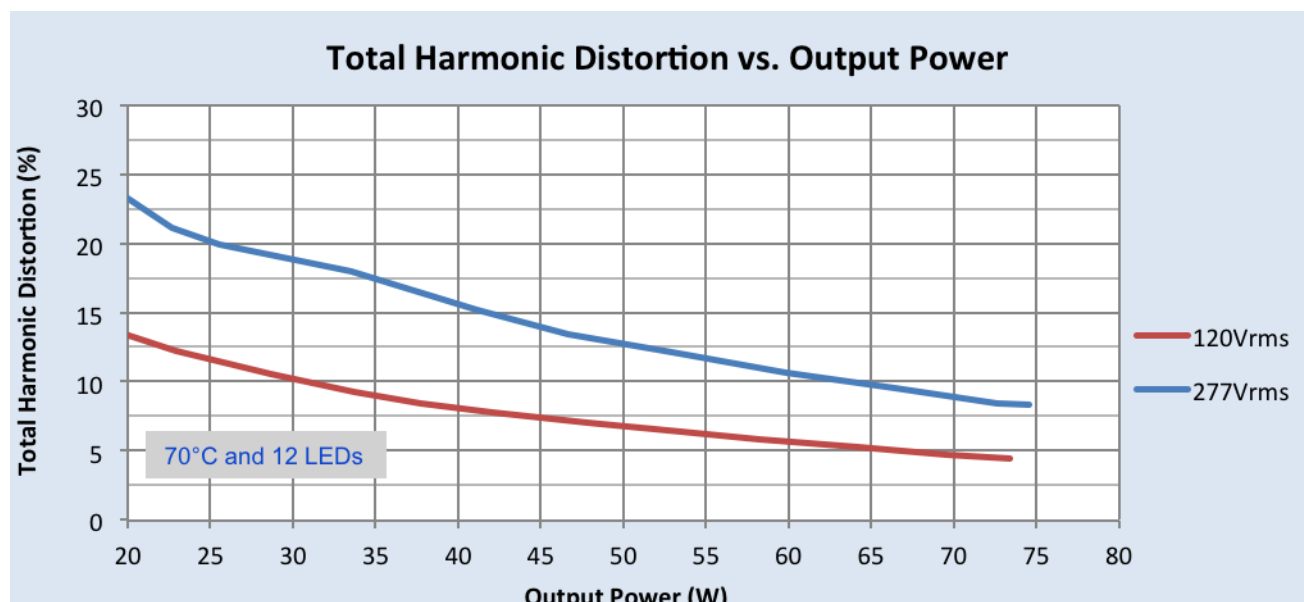

Xtanium 75W 0.1-2.0A 54V 0-10V with SimpleSet

Electrical Specifications

All the specifications are typical and at 25°C Tcase unless specified otherwise.

Iout vs. Tcase of Driver:

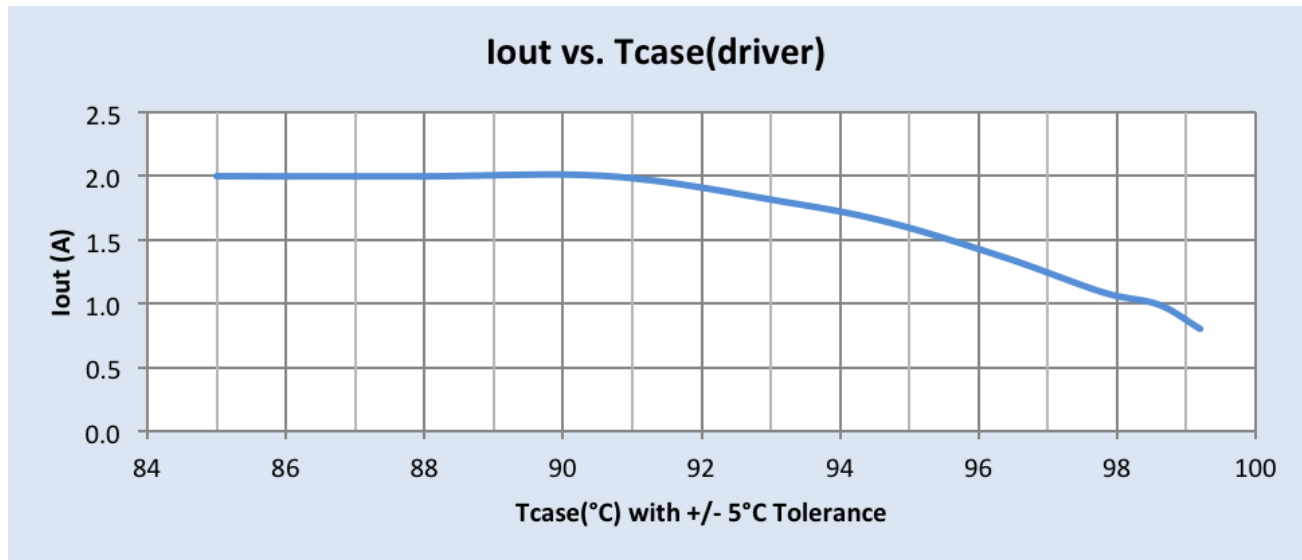

Lifetime vs. Tcase of Driver:

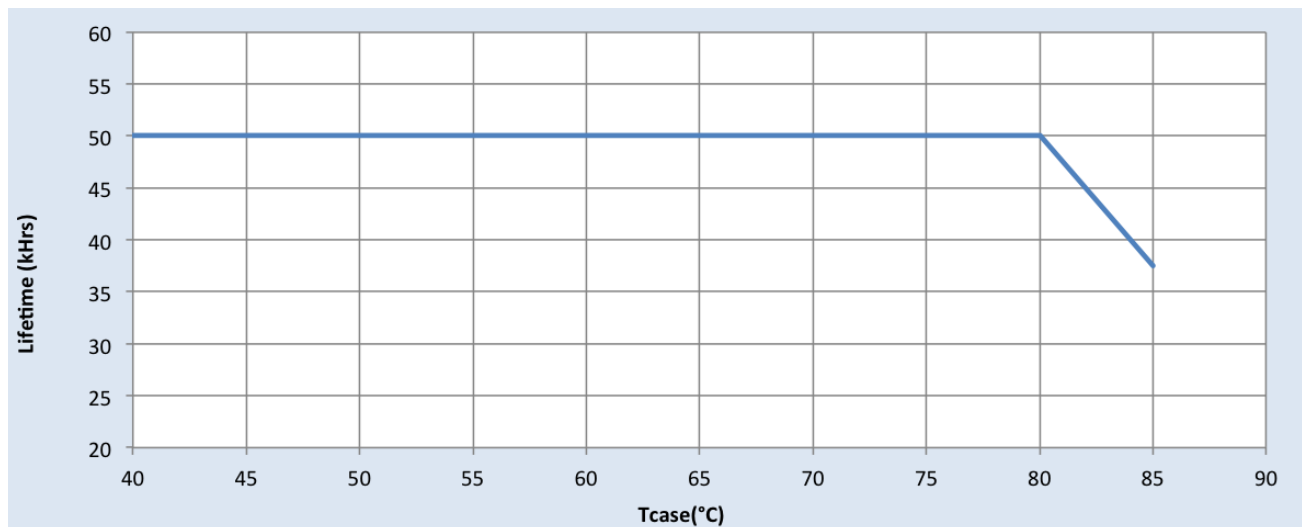

Xitanium 75W 0.1-2.0A 54V 0-10V with SimpleSet

Electrical Specifications

All the specifications are typical and at 25°C Tcase unless specified otherwise.

Inrush Current Info:

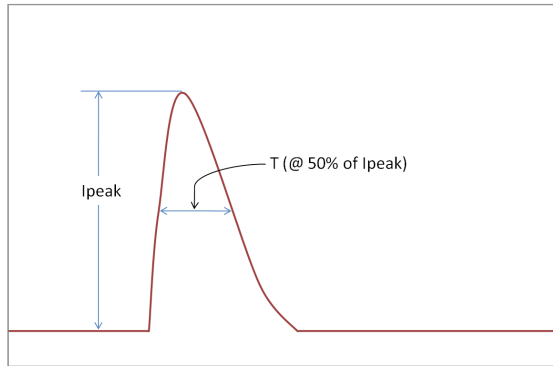

Vin	Ipeak	T (@ 10% of Ipeak)
120 Vrms	34 A	118 μs
277 Vrms	73 A	115 μs

Inrush current is measured at peak of the corresponding line voltage, source impedance per NEMA 410.

Lightning Surge Info:

ANSI Surge Type	Differential Mode (L-N)	Common Mode (L-G, N-G, L&N-G)
100 kHz Ring Wave (w/t 30Ω)	>2.5kV	>2.5kV

Isolation:

Isolation	Input	Output	0-10V (Class 2)	Enclosure
Input	NA	2xU+1kV	2.5KVac	2xU+1kV
Output	2xU+1kV	NA	Non-isolated	500V
0-10V (Class 2)	2.5KVac	Non-isolated	NA	500V
Enclosure	2xU+1kV	500V	500V	NA



© 2014 Koninklijke Philips N.V. All rights reserved.
 Philips reserves the right to make changes in specifications and/or to discontinue any product at any time without notice or obligation and will not be liable for any consequences resulting from the use of this publication.
www.philips.com/xitaniumsr



Philips Lighting North America Corporation
 10275 W. Higgins Road, Rosemont IL 60018
 Tel: 800-322-2086 Fax: 888-423-1882
 Customer/Technical Service: 800-372-3331
 OEM Support: 866-915-5886

Imported by: Philips Lighting
 A division of Philips Electronics Ltd.
 281 Hillmount Rd, Markham, ON, Canada L6C 2S3
 Tel. 800-668-9008